

Rosemount™ 3800

pH Sensors



Essential Instructions

Read this page before proceeding!

Emerson designs, manufactures and tests its products to meet many national and international standards. Because these sensors are sophisticated technical products, you **MUST** properly install, use, and maintain them to ensure they continue to operate within their normal specifications. The following instructions **MUST** be adhered to and integrated into your safety program when installing, using, and maintaining Rosemount products. Failure to follow the proper instructions may cause any one of the following situations to occur: loss of life; personal injury; property damage; damage to this sensor; and warranty invalidation.

- Read all instructions prior to installing, operating, and servicing the product.
- If you do not understand any of the instructions, contact your Emerson representative for clarification.
- Follow all warnings, cautions, and instructions marked on and supplied with the product.
- Inform and educate your personnel in the proper installation, operation, and maintenance of the product.
- Install your equipment as specified in the Installation Instructions of the appropriate Instruction Manual and per applicable local and national codes. Connect all products to the proper electrical and pressure sources.
- To ensure proper performance, use qualified personnel to install, operate, update, program, and maintain the product.
- When replacement parts are required, ensure that qualified people use replacement parts specified by Emerson. Unauthorized parts and procedures can affect the product's performance, place the safe operation of your process at risk, and **VOID YOUR WARRANTY**. Third-party substitutions may result in fire, electrical hazards, or improper operation.
- Ensure that all equipment doors are closed and protective covers are in place, except when maintenance is being performed by qualified persons, to prevent electrical shock and personal injury.

The information contained in this document is subject to change without notice.

CAUTION

Sensor/Process Application Compatibility

The wetted sensor materials may not be compatible with process composition and operating conditions. Application compatibility is entirely the responsibility of the user.

WARNING

Do not exceed temperature and pressure limitations of 284 °F (140 °C) and 72 psig (600 kPa, 6 bar).

WARNING

Before removing the sensor, be absolutely certain that the process pressure is reduced to 0 psig and the process temperature is lowered to a safe level.

CAUTION

Internal electrolyte fill solution may cause skin or eye irritation.

 **CAUTION**

Special Conditions for Safe Use

1. All pH sensors have a plastic enclosure which must only be cleaned with a damp cloth to avoid the danger due to a build up of an electrostatic charge.
2. All pH sensor models are intended to be in contact with the process fluid and may not meet the 500V r.m.s. a.c. test to earth.

This must be taken into consideration at installation.

About This Document

This manual contains instructions for installation and operation of the Rosemount 3800 pH Sensors.

The following list provides concerning all revisions of this document.

| Rev. Level | Date | Notes |
|------------|-------|--|
| D | 04/17 | Reformatted to reflect the latest Emerson documentation style Wiring Diagrams, and EC Declaration of conformity. |

Contents

| | |
|--|----|
| Section 1: Specifications | |
| 1.1 Specifications | 1 |
| 1.2 Product Certifications | 2 |
| Section 2: Installation | |
| 2.1 Unpacking and Inspection | 3 |
| 2.2 Storage | 3 |
| 2.3 Electrode Preparation | 3 |
| Section 3: Wiring | |
| 3.1 Wiring for Rosemount 3800 | 5 |
| Section 4: Calibration | |
| 4.1 Two Point Buffer Calibration | 7 |
| 4.2 Recommended pH Sensor Standardization | 7 |
| Section 5: Maintenance | |
| 5.1 Maintenance | 9 |
| Section 6: Accessories | |
| 6.1 Accessories | 11 |
| EC Declaration of Conformity | 13 |
| Intrinsically Safe Sensor Installation Drawing - FM | 15 |

Section 1: Specifications

1.1 Specifications

Table 1-1: Rosemount 3800 sensor specifications

| |
|--|
| Range |
| 0 to 14 pH |
| Temperature range |
| up to 221 °F (steam up to 284 °F) [up to 105 °C (steam up to 140 °C)] |
| Temperature sensor |
| Pt 100 |
| Wetted materials |
| Glass, ceramic and EPDM O-ring USP VI |
| Reference junction |
| Single ceramic junction |
| Dimensions |
| 12 mm OD, shaft length -01= 120 mm, -02 = 225 mm , -03 = 325 mm |
| Electrolyte |
| Gelled polymer |
| Cable connector |
| Coaxial S8 |
| Process connector |
| Pg 13.5 connector |
| Remarks |
| Suitable for all Rosemount pH-instruments. Quality certification includes list of wetted materials and calibration records |

1.2 Product Certifications

Please see online certificates for further details.

IECEX

Ex ia IIC T4 Ga (-20 °C ≤ Ta ≤ +60 °C)

Per standards IEC60079-0 : 2011, IEC 60079-11 : 2011

ATEX

⊕ II 1 G Ex ia IIC T4 Ga (-20 °C ≤ Ta ≤ +60 °C)

Per standards EN 60079-0: 2012+A11:2013, EN 60079-11:2012

FM

Intrinsically Safe for use in Class I, II, and III, Division 1, Groups A, B, C, D, E, F, and G; Temperature Class T6 Ta = -20 °C to +60 °C

Intrinsically Safe for use in Class I, Zone 0, AEx ia IIC T6 Ta = -20 °C to +60 °C

Nonincendive for use in Class I, Division 2, Groups A, B, C, and D; Temperature Class T6 Ta = -20 °C to +60 °C

Suitable for use in Class II and III, Division 2, Groups E, F, and G; Temperature Class T6 Ta = -20 °C to +60 °C Hazardous (Classified) Locations

IS/I,II,III/1/ABCDEFG/T6 Ta = 60°C - 1400332; Entity; I/O/AEx ia IIC/T6 Ta = 60°C - 1400332; Entity; NI/I/2/ABCD/T6 Ta = 60°C; S/II,III/2/EFG/T6 Ta = 60°C

Per standards 3600:1998, 3610:2010, 3611:2004, 3810:2005

CSA

Intrinsically Safe and Non-Incendive:

Class I, Division 1, Groups ABCD; Class II, Division 1, Groups EFG; Class III; Class I, Division 2, Groups ABCD; Ex ia IIC; T6; Ambient temperature rating -20°C to +60°C: (Simple Apparatus)

Per standards C22.2 No. 142 – M1987, C22.2 No 157 – M1992, CAN/CSA E60079-0:07, CAN/CSA E60079-11:02, UL 50:11th Ed., UL 508:17th Ed., UL 913: 7th Ed., UL 60079-0: 2005, UL 60079-11: 2002

Section 2: Installation

2.1 Unpacking and Inspection

Inspect the outside of the carton for any damage. If damage is detected, contact the carrier immediately. Inspect the instrument and hardware. Make sure all items in the packing list are present and in good condition. Notify the factory if any part is missing.

2.2 Storage

1. It is recommended that electrodes be stored in their original shipping containers until needed.
2. Do not store at temperatures below 23 °F (-5 °C).
3. Electrodes should be stored with a protective cap containing KCl solution (PN 9210342).
4. For overnight storage, immerse the sensor in tap water or 4 pH buffer solution.
5. A pH glass electrode does have a limited shelf life of one year.

2.3 Electrode Preparation

1. Remove electrode from shipping container.
2. Remove the protective boot covering the electrode bulb.
3. Rinse away salt film with clean water, then shake the electrode so that the internal solution fills the bulb, thus removing any air trapped there.

Note: Do not allow lubricant to coat electrode bulb or reference junction. If it does, wipe it clean before installation.

Figure 2-1: Rosemount 3800 dimensional drawing

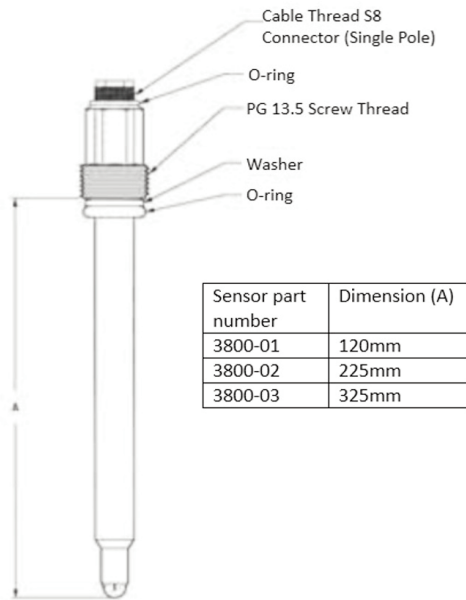
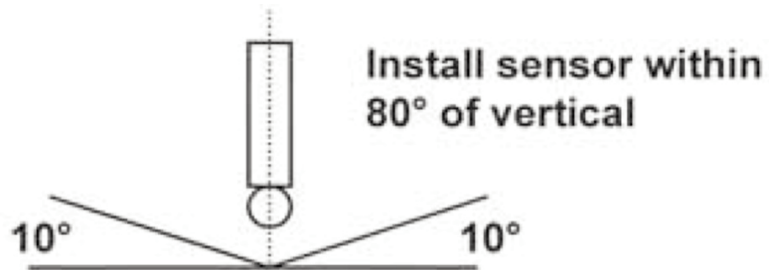

Figure 2-2: Sensor orientation



Section 3: Wiring

3.1 Wiring for Rosemount 3800

For other wiring diagrams not shown below, please refer to the [Liquid Transmitter Wiring Diagrams](#).

Figure 3-1: Rosemount 3800 sensor wiring to Rosemount 1056/56/1057 transmitters

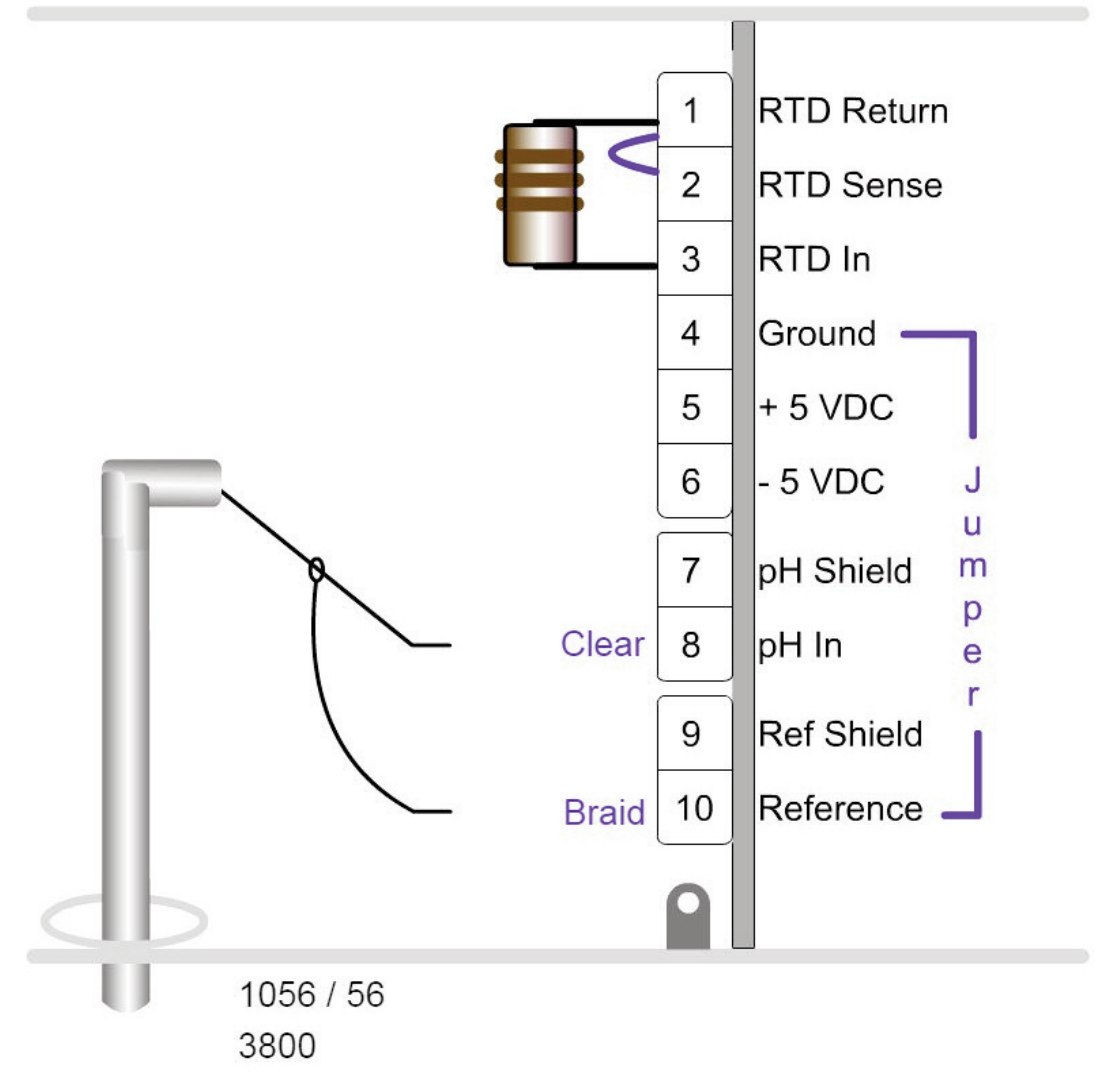

Figure 3-2: Rosemount 3800 sensor wiring to Rosemount 1066 transmitter

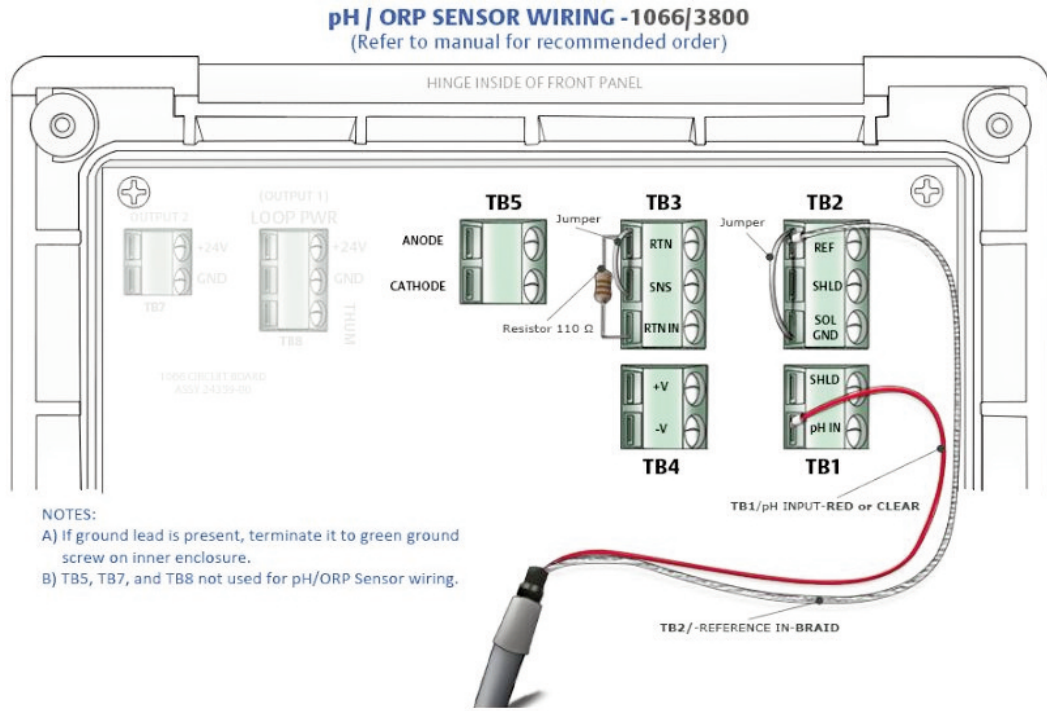
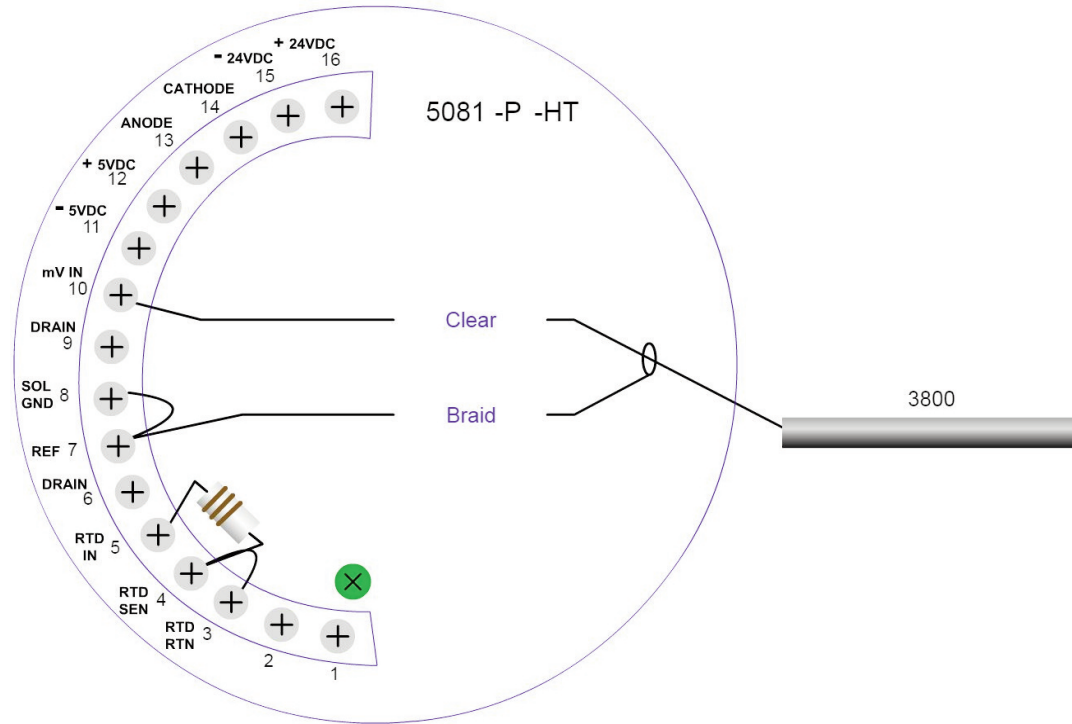

Figure 3-3: Rosemount 3800 sensor wiring to Rosemount 5081 transmitter



Section 4: Calibration

4.1 Two Point Buffer Calibration

Select two stable buffer solutions, preferably pH 4.0 and 7.0 (pH buffers other than pH 4.0 and pH 7.0 can be used as long as the pH values are at least two pH units apart).

Note: A pH 7 buffer solution reads a mV value of approx. zero, and pH buffers read approximately ± 59.1 mV for each pH unit above or below pH 7. Check the pH buffer manufacturer specifications for millivolt values at various temperatures since it may affect the actual value of the buffer solution mV/pH value.

1. Immerse sensor in the first buffer solution. Allow sensor to equilibrate to the buffer temperature (to avoid errors due to temperature differences between the buffer solution and sensor temperature) and wait for reading to stabilize. Value of buffer can now be acknowledged by transmitter.
2. Once the first buffer has been acknowledged by the transmitter, rinse the buffer solution off of the sensor with distilled or deionized water.
3. Repeat steps 1 and 2 using the second buffer solution.
4. The theoretical slope value, according to the Nernst equation for calculating pH, is approximately 59.17 mV/pH. Over time the sensor will age, both in the process and in storage, and will result in reduced slope values. To ensure accurate readings, it is recommended that the electrode be replaced when the slope value falls below 47 to 49 mV/pH.

4.2 Recommended pH Sensor Standardization

For maximum accuracy, the sensor can be standardized on-line or with a process grab sample after a buffer calibration has been performed and the sensor has been conditioned to the process. Standardization accounts for the sensor junction potential and other interferences. Standardization will not change the sensor's slope but will simply adjust the analyzer's reading to match that of the known process pH.

Section 5: Maintenance

5.1 Maintenance

Electrodes should respond rapidly. Sluggishness, offsets, and erratic readings are indicators that the electrodes may need cleaning or replacement.

1. To remove oil deposit, clean the electrode with a mild non-abrasive detergent.
2. To remove scale deposits, soak electrodes for 30 to 60 minutes in a 5% hydrochloric acid solution.
3. Temperature effect on life expectancy: If glass electrode life expectancy is 100% @ 25 °C (77 °F), then it will be approximately 25% @ 80 °C (176 °F), and approximately 5% @ 120 °C (248 °F).

Section 6: Accessories

6.1 Accessories

Table 6-1: Accessories for Rosemount 3800

| Part Number | Description |
|-------------|---|
| 9200339 | S8 cable, free rotating connector, single pole 10m long |
| 9160478 | G 1 ¼ in. x Pg 13.5 insertion adapter |
| 24167-03 | ¾ in. NPT 1 in. x Pg 13.5 insertion adapter |
| 9999SQ10057 | 1 in. NPT x Pg 13.5 insertion adapter |
| 24166-00 | EDPM O-Ring |

EC Declaration of Conformity

Note: Please see [website](#) for most recent Declaration.



EU Declaration of Conformity



(No. 1700911)

pH/ORP Sensors

This declaration is issued under the sole responsibility of the manufacturer:
Rosemount Inc., 8200 Market Blvd., Chanhassen, MN 55317 USA

The sensor models:

328A, 385, 385+ -04, 385+ -02/03, 385+ -03-12, 389-01, 389-01-10/11-50, 389-01-10/11-54, 389-01-12-50, 389-01-12-54, 389-01-12-55, 389-02, 389VP, 389VP-70, 396, 396P-01-10/13-50, 396P-01-10/13-54, 396P-01-12-50, 396P-01-12-54, 396P-01-12-55, 396P-01-55, 396VP, 396VP-70, 396R, 396RVP, 396RVP-70, 396P-02, 396PVP, 396PVP-70, 397, 398, 398VP, 398R, 398RVP, 398RVP-70, 3200HP, 3300HT, 3300HT VP, 3300HTVP-70, 3400HT, 3400HT VP, 3400HTVP-70, 3500P-01, 3500P-01-12, 3500P-02, 3500VP-01, 3500VP-01-12, 3500VP-02, 3800, 3800VP, 3900-01, 3900-02, 3900VP-01, 3900VP-02

to which this declaration relates, are in conformity with relevant Union harmonization legislation:
(2014/34/EU) ATEX Directive

Intrinsically Safe, Examination Certificate: Baseefa10ATEX0156X

Provisions of the directive fulfilled by the equipment:
Equipment Group II, Category I G Ex ia IIC T4 Ga (-20°C ≤ Ta ≤ +60°C) exceptions noted below

Model 328A Steam sterilizable pH sensor with integral cable
Model 385 Retractable pH/ORP sensor with integral cable
Model 385+ -04 pH/ORP sensor with integral cable
Model 385+ -02/03 pH/ORP sensor with integral cable & Smart preamplifier
Model 385+ -03-12 ORP sensor with integral cable & preamplifier: T4 (-20°C ≤ Ta ≤ +80°C), T5 (-20°C ≤ Ta ≤ +40°C)
Model 389-01 pH sensor with integral cable & Smart preamplifier
Model 389-01-10/11-50 pH sensor with integral cable & preamplifier: T4 (-20°C ≤ Ta ≤ +80°C) or T5 (-20°C ≤ Ta ≤ +40°C)
Model 389-01-10/11-54 pH sensor with integral cable & preamplifier: T4 (-20°C ≤ Ta ≤ +80°C) or T5 (-20°C ≤ Ta ≤ +40°C)
Model 389-01-12-50 ORP sensor with integral cable & preamplifier: T4 (-20°C ≤ Ta ≤ +80°C)
Model 389-01-12-54 ORP sensor with integral cable & preamplifier: T4 (-20°C ≤ Ta ≤ +80°C)
Model 389-01-12-55 ORP sensor with integral cable & preamplifier: T4 (-20°C ≤ Ta ≤ +80°C)
Model 389-02 pH/ORP sensor with integral cable
Model 389VP-70 pH sensor with Variopole connector & Smart preamplifier
Model 389VP pH/ORP sensor with Variopole connector
Model 396 TU pH sensor with integral cable
Model 396P-01-10/13-50 polypropylene pH sensor with integral cable & preamp: T4 (-20°C ≤ Ta ≤ 80°C) or T5 (-20°C ≤ Ta ≤ 40°C)
Model 396P-01-10/13-54 polypropylene pH sensor with integral cable & preamp: T4 (-20°C ≤ Ta ≤ 80°C) or T5 (-20°C ≤ Ta ≤ 40°C)
Model 396P-01-12-50 ORP sensor with integral cable & preamp: T4 (-20°C ≤ Ta ≤ +80°C)
Model 396P-01-12-54 ORP sensor with integral cable & preamp: T4 (-20°C ≤ Ta ≤ +80°C)
Model 396P-01-12-55 ORP sensor with integral cable & preamp: T4 (-20°C ≤ Ta ≤ +80°C)
Model 396P-01-55 pH sensor with integral cable & Smart preamp
Model 396VP TU pH sensor with Variopole connector
Model 396VP-70 TU pH sensor with Variopole connector & Smart preamplifier
Model 396R TU pH Retractable pH/ORP sensor with integral cable
Model 396RVP TU pH Retractable pH/ORP sensor with Variopole connector
Model 396RVP-70 TU pH Retractable pH sensor with Variopole connector & Smart preamplifier
Model 396P-02 TU pH Polypropylene pH/ORP sensor with integral cable
Model 396PVP TU pH Polypropylene pH/ORP sensor with Variopole connector
Model 396PVP-70 TU pH Polypropylene pH sensor with Variopole connector & Smart preamplifier
Model 397 TU pH sensor with integral cable
Model 398 TU pH pH/ORP sensor with integral cable
Model 398VP TU pH pH/ORP sensor with Variopole connector
Model 398R TU pH Retractable pH/ORP sensor with integral cable
Model 398RVP TU pH Retractable pH/ORP sensor with Variopole connector
Model 398RVP-70 TU pH Retractable pH sensor with Variopole connector & Smart preamplifier
Model 3200HP Flowing junction pH sensor with Variopole connector
Model 3300HT Insertion/submersion pH sensor with integral cable
Model 3300HTVP Insertion/submersion pH sensor with Variopole connector
Model 3300HTVP-70 Insertion/submersion pH sensor with Variopole connector & Smart preamplifier
Model 3400HT Retractable pH sensor with integral cable
Model 3400HTVP Retractable pH sensor with Variopole connector
Model 3400HTVP-70 Retractable pH sensor with Variopole connector & Smart preamplifier
Model 3500P-01 High performance pH sensor with integral cable & Smart preamplifier
Model 3500P-01-12 PerpH-X ORP sensor with integral cable & preamplifier: T4 (-20°C ≤ Ta ≤ +80°C)
Model 3500P-02 High performance pH sensor with integral cable
Model 3500VP-01 High performance pH sensor with Variopole connector & Smart preamplifier
Model 3500VP-01-12 PerpH-X ORP sensor with Variopole connector & preamplifier: T4 (-20°C ≤ Ta ≤ +80°C)
Model 3500VP-02 High performance pH sensor with Variopole connector
Model 3800 Steam sterilizable pH sensor with single pole Eurocap connector

Model 3800VP Steam sterilizable pH sensor with Variopole connector
 Model 3900-01 pH/ORP sensor with integral cable & Smart preamplifier
 Model 3900-02 pH/ORP sensor with integral cable
 Model 3900VP-01 pH sensor with Variopole connector & Smart preamplifier
 Model 3900VP-02 pH/ORP sensor with Variopole connector

Special conditions for safe use:

- 1) All pH/ORP sensor models with a plastic enclosure or exposed plastic parts may provide an electrostatic ignition hazard and must only be cleaned with a damp cloth to avoid the danger of ignition due to a build up of electrostatic charge.
- 2) All pH/ORP sensor models with a metallic enclosure may provide a risk of ignition by impact or friction. Care should be taken during installation to protect the sensor from this risk.
- 3) External connections to the sensor must be suitably terminated and provide a degree of protection of at least IP20.

All pH/ORP sensor models are intended to be in contact with the process fluid and may not meet the 500V r.m.s test to earth. This must be taken into consideration at installation.

ATEX Notified Body for EC Type Examination Certificate & Quality Assurance:

SGS Baseefa[Notified Body Number:1180], Rockhead Business Park, Staden Lane, Buxton SK17 9RZ UNITED KINGDOM

Assumption of conformity is based on the application of the harmonized standards:

EN 60079-0:2012+A11:2013 Explosive atmospheres. Equipment. General requirements

EN 60079-11:2012 Explosive atmospheres. Equipment protection by intrinsic safety "i"

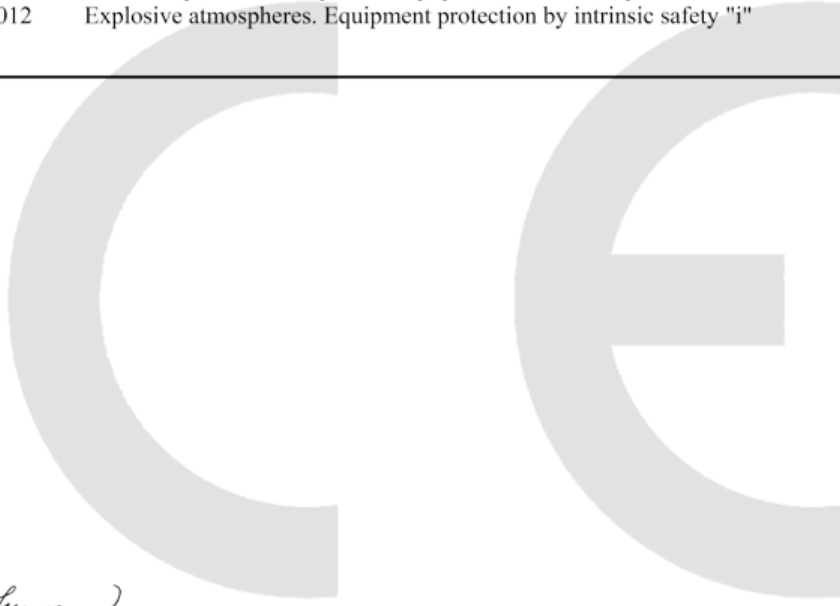

Kim Freeman

(Signature)

Kim Freeman
(Name printed)

Director of Global Quality

(Function name)

March 23, 2017
(Date of issue)

CE marking was first affixed to this product in 2011

Intrinsically Safe Sensor Installation Drawing - FM

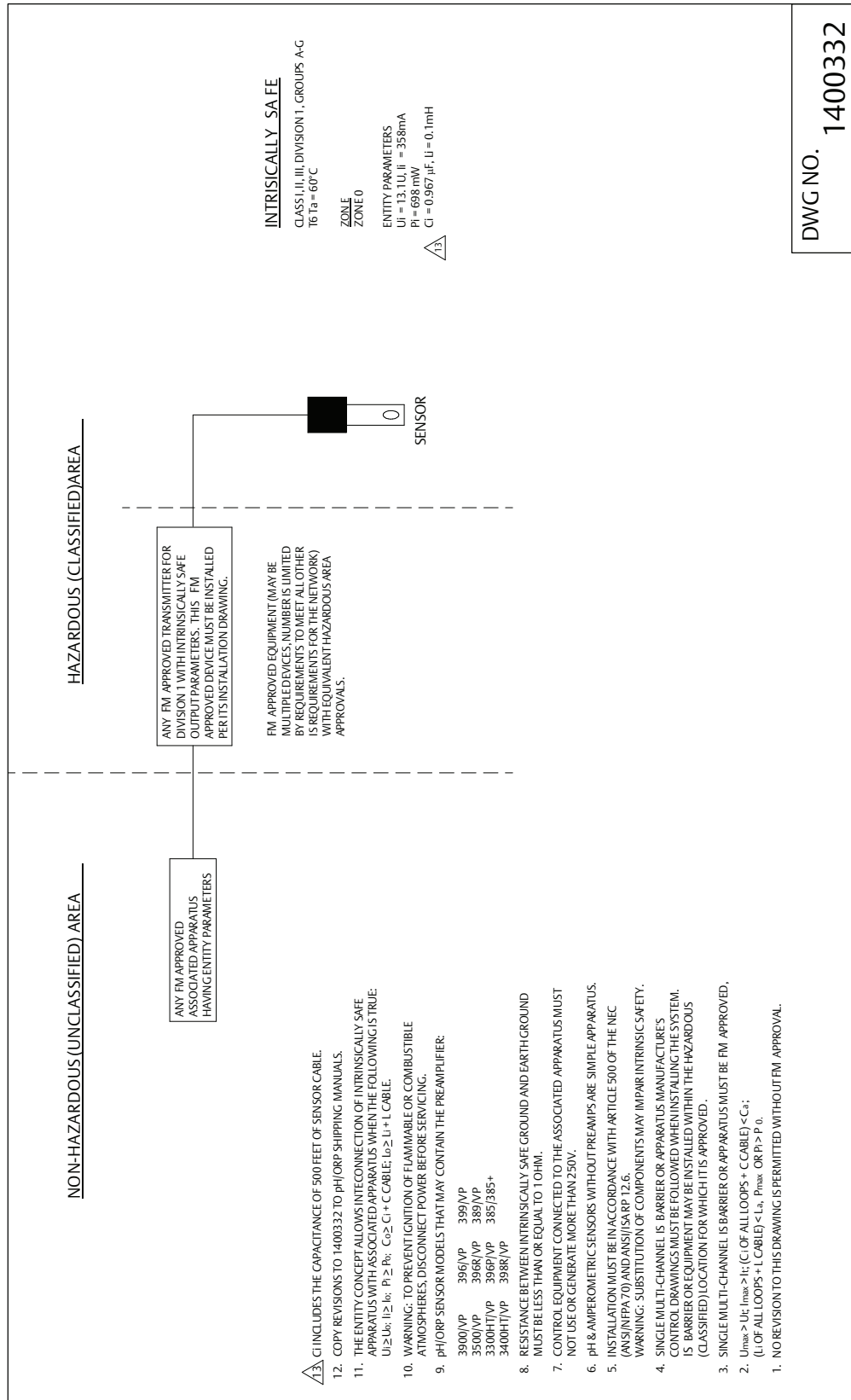

DWG NO. 1400332

www.Emerson.com/RosemountLiquidAnalysis



[Youtube.com/user/Rosemount](https://www.youtube.com/user/Rosemount)



Analyticexpert.com



[Twitter.com/Rosemount_News](https://twitter.com/Rosemount_News)



facebook.com/Rosemount

Emerson

8200 Market Blvd.
Chanhassen, MN 55317,
USA
Tel +1 800 999 9307
Fax +1 952 949 7001

Liquid.CSC@Emerson.com

©2017 Emerson. All rights reserved.

The Emerson logo is a trademark and service mark of Emerson Electric Co. Rosemount is a mark of one of the Emerson family of companies. All other marks are the property of their respective owners.

The contents of this publication are presented for information purposes only, and while effort has been made to ensure their accuracy, they are not to be construed as warranties or guarantees, express or implied, regarding the products or services described herein or their use or applicability. All sales are governed by our terms and conditions, which are available on request. We reserve the right to modify or improve the designs or specifications of our products at any time without notice.