

Bedienungsanleitung

Instruction Manual

Elektrische Antriebe Typ EA25-250
Electric Actuators Type EA25-250



Original instruction manual

Observe instruction manual

The instruction manual is part of the product and is an important element of the safety concept.

- ▶ Read and follow the instruction manual.
- ▶ Always keep the instruction manual available at the product.
- ▶ Pass on the instruction manual to all subsequent users of the product.

Contents

Original instruction manual.....	39
Contents.....	40
1 Intended use	42
2 About this document	42
2.1 Warnings	42
2.2 Other related documents	43
2.3 Product variants and types described	43
2.4 Abbreviations	43
3 Safety and responsibility	44
4 Transport and storage.....	44
5 Design and function.....	45
5.1 Design	45
5.2 Identification	46
5.3 Principle of operation	46
5.3.1 Position indicator.....	47
5.3.2 LED status feedback.....	48
5.3.3 Buttons for setting the end positions	49
5.3.4 Overload protection	50
5.3.5 Safety position.....	50
5.3.6 Heating element	50
5.3.7 Emergency manual override.....	50
5.4 Wiring diagram EA25/45/120/250	51
5.5 Dimensional drawing of interfaces.....	52
6 Technical specifications	53
7 Installation	53
7.1 Installing the actuator with valve.....	54
7.1.1 Preparation and assembly	56
7.1.2 Connecting the actuator.....	56
8 Commissioning	58
8.1 Putting the actuator into operation	58
9 Operation.....	59
9.1 Insert the emergency manual override hand crank	59
9.1.1 Preparation	60
9.1.2 Procedure	60
9.2 Adjusting end positions	61

9.3	Inverting LED color assignment	61
9.4	Adjusting the heating element	62
9.5	Performing a factory reset	63
9.6	Teaching in the position sensor (learning run)	63
10	Help in case of faults	64
10.1	Fault message indicator	64
10.2	Assignment of error codes	65
10.3	Troubleshooting	66
11	Maintenance	67
12	Spare parts list	68
13	Accessories	69
14	EC declaration of incorporation	70
15	Disposal	71

1 Intended use

The electric actuators EA 25/45/120/250 are designed for assembly on a valve and for connection to a system controller.

The electric actuators EA 25/45/120/250 are intended to activate valves with rotating movements up to 180° (e. g. ball valves and butterfly valves).

The product is not intended for any types of use other than those described here. Non-observance of the instructions contained in this manual will void the manufacturer's warranty for the products mentioned above.

2 About this document

This document contains all the information necessary for installation, operation and maintenance of the product.

2.1 Warnings

This instruction manual contains warnings that indicate a risk of death, injury, or material damage. Always read and observe to these warnings!

⚠ WARNING**Risk of serious physical injury!**

Non-observance will lead to a possible risk of fatal or serious physical injury!

⚠ CAUTION**Risk of minor physical injury!**

Non-observance will lead to a risk of physical injury!

ATTENTION**Risk of damage to property!**

Non-observance will lead to a risk of damage to property (loss of time, loss of data, machine damage, etc.)!

Other symbols

Symbol	Meaning
1.	Call for action in a certain order: Here, you have to do something.
▶	Call for action without fixed order.
	Remarks: Contain especially important information for better understanding.

2.2 Other related documents

- Georg Fischer industrial planning fundamentals
- Assembly instructions accessories
- Assembly instructions of the respective manual valve

These documents can be obtained via the agency of GF Piping Systems or under www.gfps.com.

2.3 Product variants and types described

- Type EA25 24V AC/ DC and 100 – 230V AC
- Type EA45 24V AC/ DC and 100 – 230V AC
- Type EA120 24V AC/ DC and 100 – 230V AC
- Type EA250 24V AC/ DC and 100 – 230V AC

2.4 Abbreviations

Abbreviation	Description
EA	Electric actuator
AC/DC	Alternating Current/Direct Current
SELV	Safety Extra Low Voltage
CW	Clockwise
CCW	Counter Clockwise
NO	Normally open contact
NC	Normally closed contact
BCD	Binary coded decimals
SMD	Surface Mounted Device

3 Safety and responsibility

- ▶ Only use the product for the intended purpose, see Intended Use.
- ▶ Do not use the product if it is damaged or faulty. Sort out the product immediately or obtain service if damaged.
- ▶ Product and accessories only to be operated by persons, who have the necessary training, knowledge or experience.

The following target groups are addressed in this instruction manual:

- **Operators:** Operators are instructed in the operation of the actuator and observe the safety guidelines.
 - **Service staff:** The service staff have been professionally trained and carry out maintenance work.
 - **Electrically qualified person:** Persons who work on the electrical equipment must be technically trained and qualified.
- ▶ Regularly instruct personnel on all questions regarding the local regulations applying to occupational safety and environmental protection, especially for pressurized pipelines.
 - ▶ Make sure that personnel know, understand and follow the instruction manual and the instructions contained therein.
 - ▶ Observe the instruction manual for the manual valve. They are an integral component of this manual.
 - ▶ Take precautions against electrostatic hazards.

4 Transport and storage

- ▶ Protect the product against external forces during transport (impacts, knocks, vibrations, etc.).
- ▶ Transport and/or store the product in its unopened original packaging.
- ▶ Protect the product from dust, dirt, moisture as well as heat and ultraviolet radiation.
- ▶ Ensure that the product is not damaged either by mechanical or thermal influences.
- ▶ Before assembly, check the product for damage during transport.

5 Design and function

5.1 Design

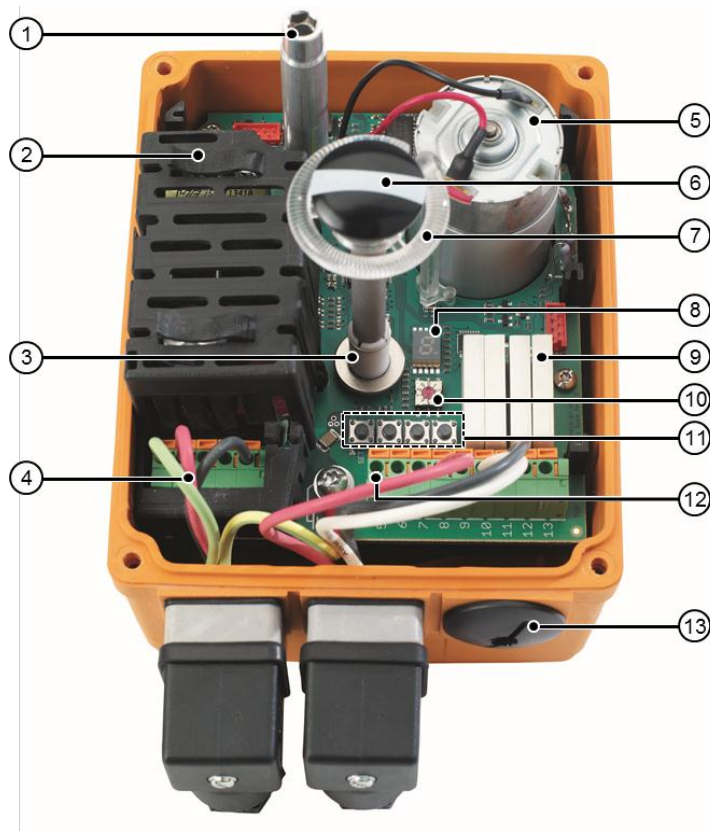

Item	Name	Item	Name
1	Shaft for emergency manual override hand crank	8	7 segment error display
2	Power supply with cover (100 – 230 V version shown)	9	Position feedback via relay for OPEN/CLOSE/MIDDLE/ready-to-operate
3	Digital position detection	10	Heating element (temperature threshold control)
4	Control power for OPEN/CLOSE/MIDDLE position	11	Button for end position adjustment
5	DC motor	12	Signal output "Ready-to-operate"
6	Optical position indicator	13	Connections for DIN plug or cable gland
7	Light tube for LED status feedback		

5.2 Identification

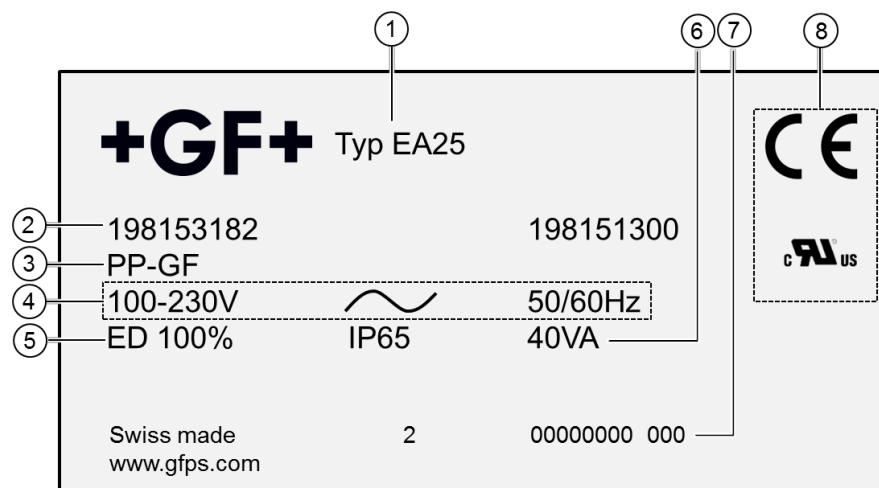

No.	Designation	No.	Designation
1	Type plate (e. g. EA25)	5	Duty cycle/protection rating
2	Assembly number	6	Nominal power
3	Housing material	7	Serial number
4	Voltage type	8	Approvals & CE-mark

5.3 Principle of operation

The actuator runs by switching the voltage from the OPEN position to the CLOSE position. By switching the voltage to the other input, the actuator runs from the CLOSE position to the OPEN position.

The end positions are factory set to 0 and 90°. Additionally, any 3rd position (MIDDLE position) can be adjusted, which is located between the OPEN position and the CLOSE position. This position is not assigned at the factory.

End positions and Middle position can later be changed via the end position buttons, see Chapter 9.2 "Adjusting end positions", Page 61.

5.3.1 Position indicator

The position indicator shows the valve position. The valve positions can be read on the installed cover.

i GF actuators are always delivered in the OPEN position.

When the cover is installed, the following image can be seen (Example ball valve):

	2-way	3-way horizontal (L)	3-way vertical (L)
Image of position indicator in valve-position 1			
Valve function			
Actuating angle	0° - 90°	0° - 90°	0° - 180°
Valve-position 1	A-B (OPEN)	A-C (Flow right side, outlet to the front)	B-C (Flow left side, bottom outlet)
Valve-position 2	C-D (CLOSE)	B-C (Flow left side, outlet to the front)	A-C (Flow right side, bottom outlet)

5.3.2 LED status feedback

The LED status feedback shows the valve positions and the current status of the actuator.

The following table shows the color assignment of the LED:



LED status feedback on the actuator

Color	Meaning
Red	OPEN position
Green	CLOSE position
White	MIDDLE position
Flashes white	Actuator moves
Flashes yellow	Fault
Flashes blue	Learning mode
Green/yellow	Setpoint value reached (at positioner)
Turquoise	Adjustment run / operation of color inversion

If the plant standard requires an inversion of the color assignment, the customer can adjust this afterwards, see Chapter 9.3 "Inverting LED color assignment", Page 61.

5.3.3 Buttons for setting the end positions

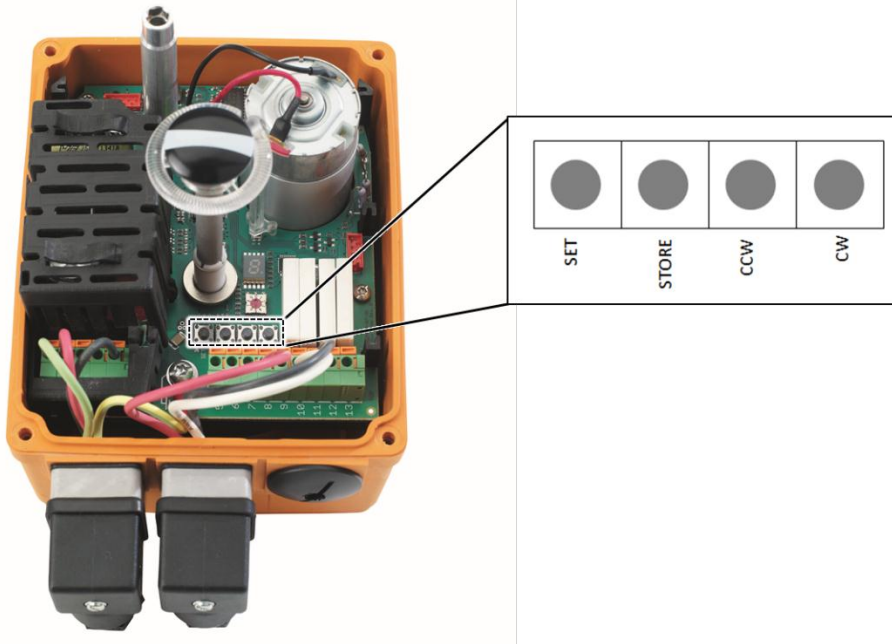

Buttons for setting the end positions inside the actuator

The following table describes the functions of buttons shown above:

Button	Adjustment mode ("SET" button pressed for 3 s)	Standard mode (terminal 4 permanently energized)	Error mode
SET	Press the button, until the color of the LED of which the assigned position is to be changed lights up (e. g. green – CLOSE)		Acknowledge the error (instead of disconnecting the power supply)
STORE	Saving the position moved to	Moving to position CLOSE	
CCW	Moving counterclockwise	Moving to position MIDDLE	
CW	Moving clockwise	Moving to position OPEN	

The following table describes the functions of button combinations:

Button combination (press ~3s)	Function	Action
SET + CCW	LED color assignment	Inverting colors
SET + CW	Factory reset	Actuator will be set to the values predefined at the factory
SET + STORE	Learning run / new adjustment of the position sensor (if magnet position has been twisted or after exchanging boards)	Deleting the taught in positions

5.3.4 Overload protection

The supply unit of the EA 25/45/120/250 has an overload protection that protects the DC motor and the power supply from overheating. The overload protection is activated as soon as the load exceeds the torque range. The actuator motor resumes as soon as the load is in the torque range and the temperature/current has gone down.

5.3.5 Safety position

During a power outage, the actuator remains in its current position. If the actuator is fitted with the "fail-safe return unit" accessory, it can automatically move to a predefined safety position (OPEN or CLOSE), in case of a power outage.

5.3.6 Heating element

The integrated heating element prevents condensation or icing inside the housing. It starts heating from a preset value. The value depends on the ambient temperature, at which the actuator is operated, and can be set manually. The default setting is <0 °C / <32 °F. When the heating element is active, the dot on the 7 segment display is illuminated.

5.3.7 Emergency manual override

The integrated emergency manual override is used to run the actuator manually into another position. The integrated emergency manual override allows the operation of the actuator to be maintained for a short time if there is no current applied, e. g. during putting into operation or during a power outage.

5.4 Wiring diagram EA25/45/120/250

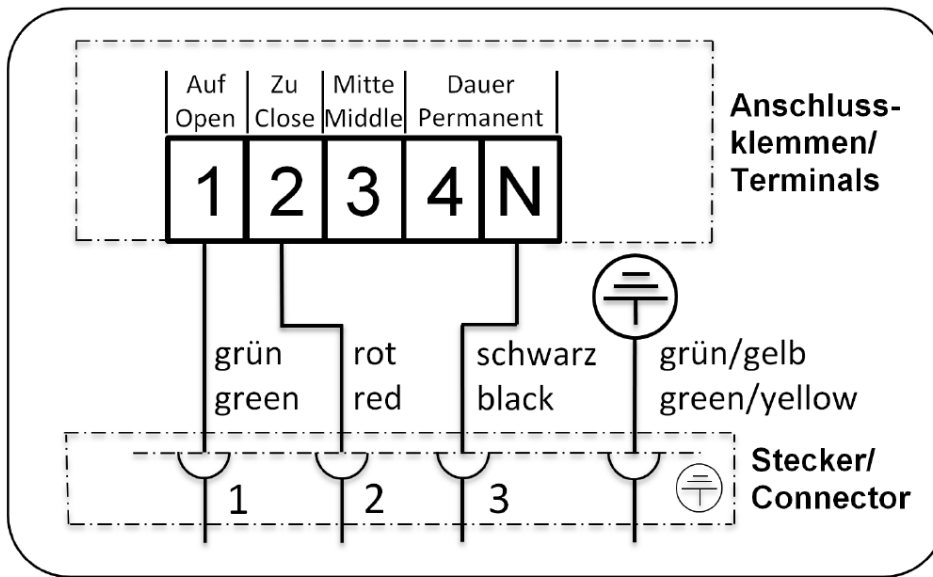

Connection of the voltage supply for positions OPEN, CLOSE and MIDDLE

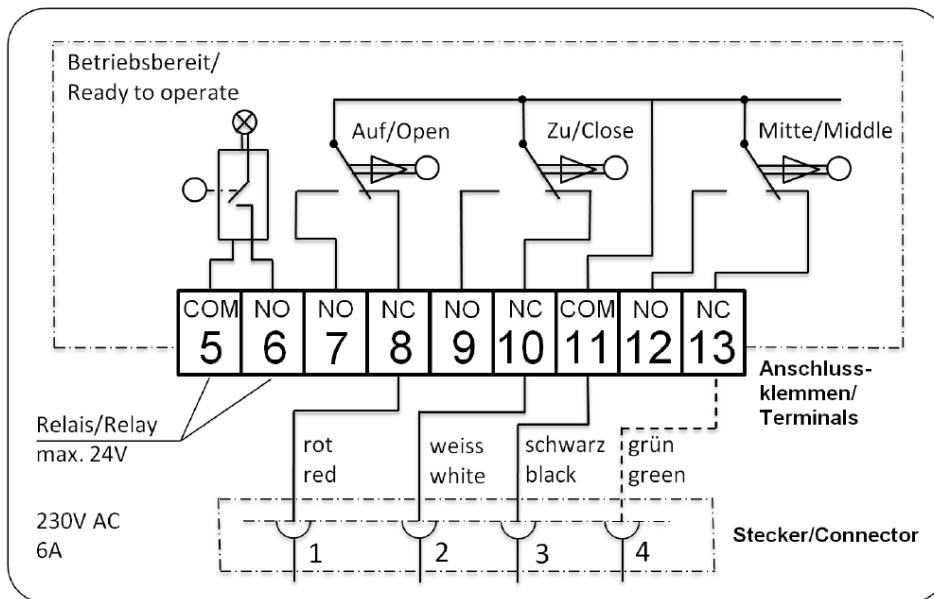

Connection of position feedback for positions OPEN, CLOSE and MIDDLE (optional)

i Ex factory, the position feedback is wired as a normally closed contact (NC). On site, this might also be implemented as a normally open contact (NO), subsequently.

i Standard delivery is with a unit plug for position feedback OPEN/CLOSE. A unit plug with additional pin for MIDDLE feedback can be ordered as an accessory or special configuration. Each actuator is provided with this functionality. Connection via cable gland is also possible.

5.5 Dimensional drawing of interfaces

EA 25/45 → Flange fitting F05

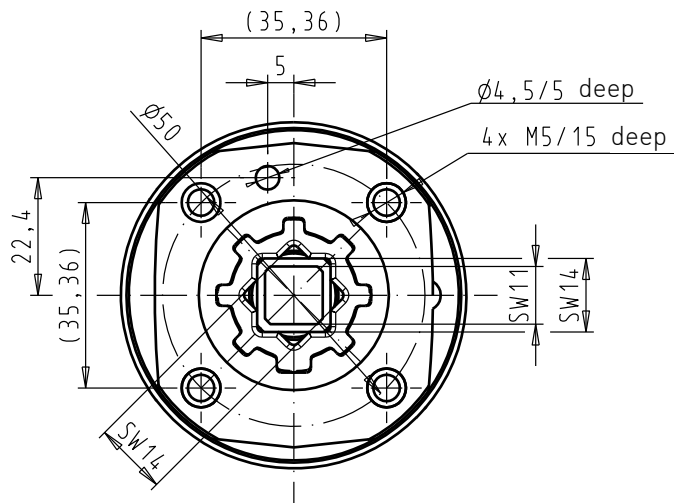

EA 120 → Flange fitting F07

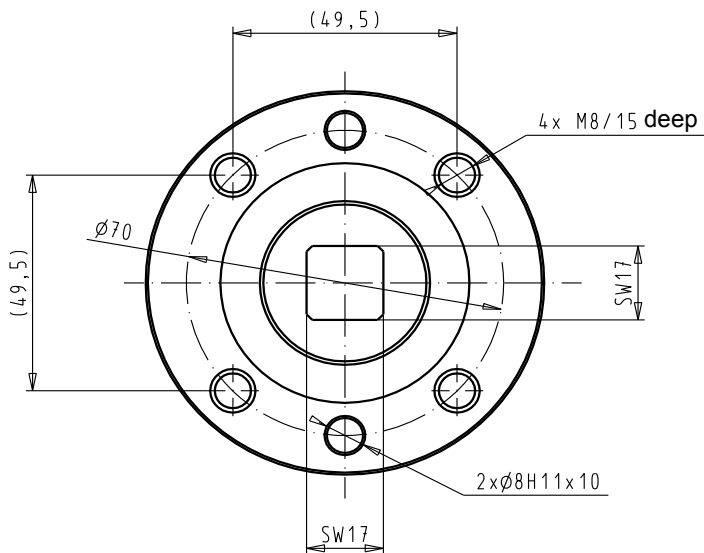

EA 250 → Flange fitting F07

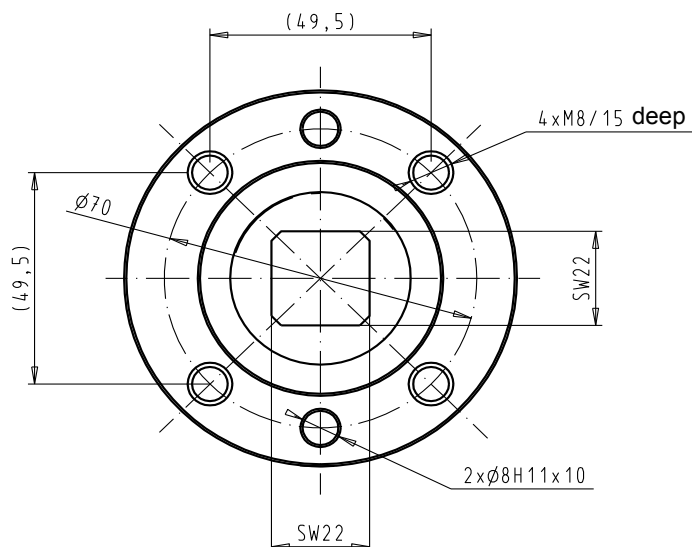

6 Technical specifications

	EA 25	EA 45	EA 120	EA 250
Nominal power	AC: 35 VA at 100 – 230 V	AC: 55 VA at 100 – 230 V	AC: 50 VA at 100 – 230 V	AC: 60 VA at 100 – 230 V
	AC/DC: 40 VA at 24 V	AC/DC: 60 VA at 24 V	AC/DC: 55 VA at 24 V	AC/DC: 65 VA at 24 V
Nominal torque M_{dn} (peak)	10 [25] Nm	20 [45] Nm	60 [120] Nm	100 [250] Nm
Duty cycle	100 %	50 %	50 %	35 %
Cycle time s/90° at M_{dn}	5 s	6 s	15 s	20 s
Flange fitting	F05	F05	F07	F07
Tested cycles (at 20 °C and M_{dn})	250 000	100 000	100 000	75 000
Weight	2.1 kg	2.2 kg	3.6 kg	5.0 kg
Actuating angle	Max. 355°, set to 90°			
Nominal voltage	AC: 100 – 230 V, 50/60 Hz			
	AC/DC: 24 V, 50/60 Hz			
Nominal voltage tolerance	± 15 %			
Protection class	IP 65 (IP67) ¹⁾ according to EN 60529			
Pollution degree	2 according to EN 61010-1			
Overload protection	Current/time dependent, resetting			
Overvoltage category	II			
Fuse	SMD fuse 2 A, not replaceable			
Ambient temperature	-10 °C to +50 °C			
Allowable humidity	Max. 90 % relative humidity, non condensing			
Housing material	PP-GF for very good chemical resistance			





¹⁾ When used with cable glands and vertical installation

7 Installation

If a complete valve is supplied, no mounting activities and adjustments are required. The actuator can directly be put into operation, see Chapter 8 “Commissioning” Page 58. When assembled by the customer, the actuator must be assembled, connected, and, if necessary, adjusted.

7.1 Installing the actuator with valve

The actuators have a standard ISO 5211 interface, and can therefore be mounted on all valves that are provided with this interface and the appropriate torques. The assembly using valves from GF Piping Systems with suitable coupling piece and adapter is possible in accordance with the following table:

	EA 25	EA 45	EA 120	EA 250
				
2-way ball valve to DN 50 e. g. ball valve type 546 DN10-DN50 / 3/8 – 2 inch	✓	–	–	–
2-way ball valve to DN 100 e. g. ball valve type 546 DN65-DN100 / 2 1/2 - 4 inch	–	✓	✓	–
3-way ball valve to DN 50 e. g. ball valve type 543	✓	–	–	–
Butterfly valves e. g. butterfly valve type 567/578	–	✓	✓	✓

Valve	2-way ball valve							3-way ball valve				Butterfly valve			
Type	546							543				567	578		
+ Actuator EA	11	25 DN10 – DN50 / 3/8 – 2 inch 45 DN65 / 2 ½ inch 120 DN80 - DN100 / 3 – 4 inch						25				45 to DN65 / 2 ½ inch 120 to DN150 / 6 inch 250 from DN200 / 8 inch			
= Type	107	179	180	181	182	183	184	167	168	169	170	145	146	147	
Remark	metric	metric	metric	metric	ANSI	BS	JIS	horizontal	horizontal	horizontal	vertical	Wafer	Lug	Lug ANSI	Lug JIS
PVC-U	x	x			x	x	x	x			x	x	x	x	x
PVC-C	x	x			x	x	x	x				x	x	x	x
ABS	x	x			x	x	x	x				x	x	x	x
PP-H	x		x		x	x	x		x			x	x	x	x
PVDF	x			x	x	x	x			x		x	x	x	x

i Installation and assembly of the actuator may only be carried out by electrically qualified persons, see Chapter 3 “Safety and responsibility”, Page 44.

7.1.1 Preparation and assembly

- ▶ In addition to this manual, please also follow the specifications of the valve manufacturer.
- ▶ Before installation, compare the technical data of the actuator with those of the control and the valve. Only install the actuator if the data match.
- ▶ Before installation, check plugs and terminals for possible damage.
- ▶ Make sure that no damaged parts are used.
- ▶ Mount the actuator on the valve, see assembly instructions of the respective manual valve.
- ▶ If the actuator for the system requires protection class IP67, implement the following measures:
 - Use cable glands.
 - Fit the actuator vertically.
- ▶ If the device is directly controlled, implement the following measures:
 - Fit a circuit breaker on site.
 - Do not connect earth ground conductor.

7.1.2 Connecting the actuator



Voltage too high!

Danger of injury and/or damage to property.

- ▶ Make sure that 24 V devices are only connected to voltages that meet the requirements of a safety extra low voltage circuit (SELV).
-

NOTE

Damage to the actuator by short circuit or corrosion!

Moisture and/or dirt in the actuator.

- ▶ Make sure that no water enters the actuator.
 - ▶ Mount the cable routing, so it does not point upwards.
-

Requirements

- Wire gauge max. 1.5 mm²
- Wire gauge min. 0.75 mm²
- Sizing of the fuse: > 6 A

1. Connect the unit plug for the power supply and the unit plug for position feedback according to wiring diagram, see Chapter 5.4 "Wiring diagram EA25/45/120/250", Page 51. Make sure that the cable routing does not point upwards.

NOTE**Premature component wear, error signals and false fail safe return signals due to faulty control!**

If the voltage is removed when reaching the end position, the status signal of the end position is omitted and the actuator controls again the now energized position. This causes the LED to flash red or green, as well as premature relay wear.

- ▶ During normal operation avoid switching off the control power to the actuator.
E.g. connect the inputs OPEN/CLOSE as a changeover contact

-
2. If necessary, connect the ready for operation monitoring (terminal 5.6 NO), see Chapter 5.4 "Wiring diagram EA25/45/120/250", Page 51.
 3. If necessary, adjust the end positions, see Chapter 9.2 "Adjusting end positions", Page 61.
 4. If necessary, adjust the heating element, see Chapter 9.4 "Adjusting the heating element", Page 62.

Upon delivery, the heating element is set as follows:

T < 0 °C → heating element is heating

T > 5 °C → heating element switches off again

If required, the switch-on threshold can be set up to 40 °C.

8 Commissioning

Before putting the system into operation, a functional test of the actuator must be carried out.

Requirements

- The actuator is not connected to power.
 - ▶ Make sure that the supply voltage matches the details on the type plate.
 - ▶ Make sure that the actuator is connected properly.
 - ▶ Check fuse: > 6 A.
 - ▶ Check that the valve position matches the position indicator of the actuator.
 - ▶ Make sure that actuator and valve are connected correctly and tightly with each other.



Using the emergency manual override hand crank, the valve can also be opened or closed without power, see Chapter 9.1 “Insert the emergency manual override hand crank”, Page 59.

8.1 Putting the actuator into operation



Too high current peaks during the actuator is switched on due to charging of the mains capacitor!

Danger of injury and/or malfunction.

- ▶ Connect and operate the actuator as per wiring diagram, see Chapter 5.4 “Wiring diagram EA25/45/120/250”, Page 51.
-

1. Connect the actuator to appropriate power.
The ready for operation signal appears.
2. If necessary, make further settings, e. g. invert the LED color assignment, adjust the end positions and set the heating element, see Chapter 9 “Operation”, Page 59.



In case of a malfunction, the “ready-to-operate” signal goes out (normally contact) and a fault message is indicated at the 7 segment display, see Chapter 10.1 “Fault message indicator”, Page 64.

9 Operation



Working with removed cover on the actuator!

Danger of injury and/or damage to property.

- ▶ Disconnect connections of the feed and control voltage.
- ▶ Only carry out adjustments on live parts with specially insulated tools.

9.1 Insert the emergency manual override hand crank

The emergency manual override hand crank can be turned clockwise or counterclockwise. The direction depends on whether the valve is to be opened or closed.

Direction of rotation	Function
Clockwise (CW)	close
Counter clockwise (CCW)	open

Depending on the type of actuator a different number of rotations at the crank handle is necessary, in order to open or close the valve. The following table shows how many rotations are necessary for the respective type:

Type	Number of rotations	Angle
EA 25	9	90°
EA 45	9	90°
EA 120	27	90°
EA 250	41	90°





Unintentional restarting of the actuator!

Danger of injury due to rotation of the actuator if powered while emergency manual override hand crank is installed.

- ▶ If possible, disconnect the unit plug during manual operation or disconnect the actuator in another way.

9.1.1 Preparation

Step 1	Step 2	Step 3
		
<p>Pull the crank handle (1) out of the holder.</p>	<p>Remove cover screw (2) with crank handle (1). The magnet centers the position. The cover screw sticks magnetically at the crank handle.</p>	<p>Insert crank handle into the hexagon under the opening.</p>

9.1.2 Procedure

1. Remove power to actuator by disconnecting DIN plug.
2. Press hand crank to the stop. The crank engages.
If the actuator is still energized, the "ready-to-operate" signal will go out.
3. To open or close the valve, turn the crank handle according to the above tables.
4. In order to put the actuator back into normal operation, remove the crank handle **(1)**.
Apply power by reinstalling DIN plug. After 3 seconds, the actuator will start up.

NOTE

Damage to the actuator by short circuit or corrosion!

Moisture and/or dirt in the actuator.

- ▶ Make sure that no water has entered the actuator.

5. Screw on cover screw **(2)** again.
6. Put crank handle **(1)** back into the holder.

9.2 Adjusting end positions

i If an end position is not reached, the actuator automatically switches off after 2 min. and displays a fault message.

The two end positions in the actuator have been factory set to 90°. A readjustment may be required after assembly by the customer or after repair work.

The end positions can be set via the 4 buttons on the base board.

1. Open cover. To do so, loosen the 4 screws (torx size 20).
2. Connect the actuator to the appropriate power and let it rotate, until an end position is reached.
3. Press the SET button and hold it for 3 seconds. The LED status feedback starts flashing blue (adjustment mode).
4. Press the SET button again. With each pressing, the LED goes through the following color combinations:

Color combination	End position
Blue/red	OPEN
Blue/green	CLOSE
Blue/white	MIDDLE

5. Press the SET button, until the desired color combination of the end position to be set is displayed.
6. Move the actuator to the desired position by using the CCW and CW buttons.
7. Save the position by using the STORE button.
8. Repeat this process, until all positions are adjusted.
9. Reinstall the cover and fasten it with the 4 screws.

9.3 Inverting LED color assignment

The LED color assignment has been set at the factory to red = OPEN, and green = CLOSE. This assignment can be inverted by the customer, if desired.

1. Open cover. To do so, loosen the 4 screws (torx size 20).
2. Make sure that the actuator is connected to appropriate power.
3. Press the SET + CCW buttons and hold them for 5 seconds.
The LED lights up turquoise. The colors red and green are inverted.
4. Reinstall the cover and fasten it with the 4 screws.

9.4 Adjusting the heating element

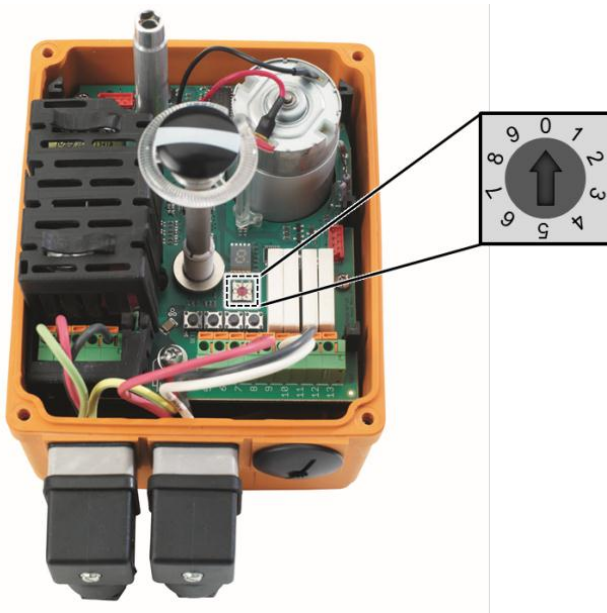

Heating adjustment inside the actuator

The heating element has been set at the factory, so it starts heating from an internal device temperature of 0 °C. For environments with higher temperatures and high humidity, the heating threshold must be increased, in order to prevent moisture condensation inside the housing. The heating threshold can be set via the heating adjustment.

The following table shows the positions of the heating adjustment and in which corresponding temperature ranges the heating element will heat.

Position heating adjustment	Heating on (°C)	Heating off (°C)
0 (default)	< 0	< 5
1	5	10
2	10	15
3	15	20
4	20	25
5	25	30
6	30	35
7	35	40
8	40	45
9	40	45

- ▶ In order to change the heating threshold, turn the heating adjustment with a suitable screwdriver to the desired position.



When the heating element is active, the dot on the 7 segment display is illuminated.

9.5 Performing a factory reset

When performing a factory reset, all previously saved positions will be deleted, and a possible color inversion will be cancelled.

1. Open cover. To do so, loosen the 4 screws (torx size 20).
2. Press the SET + CW buttons.
The factory reset is performed.

9.6 Teaching in the position sensor (learning run)

NOTE

Damage of actuator, valve or intermediate element!

- ▶ During the learning run of the position sensor, make sure that there are no structures blocking the several 360° rotations of the actuator. If necessary, dismount the actuator from the valve.

1. Open the cover. To do so, loosen the 4 screws (torx size 20).
2. Press the SET + STORE buttons and hold them for 3 seconds.
The actuator does several rotations.
After completion of the learning run, the LED status feedback lights up yellow, if there were no end positions saved before.
3. Readjusting the end positions, see Chapter 9.2 “Adjusting end positions”, Page 61.
4. Reinstall the cover and fasten it with the 4 screws.

10 Help in case of faults

10.1 Fault message indicator

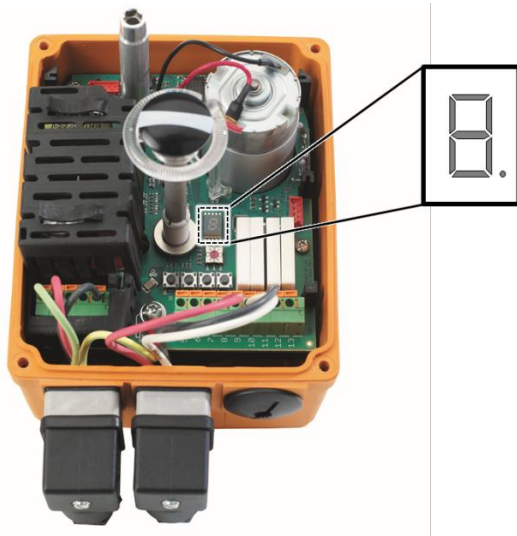

7 segment display on the base board

In case of a fault message, the following events occur:

- The LED flashes yellow (except during a power outage).
- The “ready-to-operate” signal (terminal 5.6 NO) drops.
- The 7 segment display is illuminated on the base board, see Chapter 10.2 “Assignment of error codes”, Page 65.
- If the monitoring accessories are installed, the LED on the BCD switch, of which the set value has been exceeded, will also light up.

10.2 Assignment of error codes

In case of a fault, the error codes will be displayed on the 7 segment display on the base board.

Error code	Description	“Ready-to-operate” signal	EA response
-----	No voltage	No	None
U	Voltage below specification	No	None
0	Housing internal temperature too high (>80 °C)	No	Stops
5	Time from end position to end position too long (> 120s)	No	Stops
b	Voltage above specification	No	Stops
h	Heating defective and T = < 0 °C	No	Normal operation
e	Error in position detection	No	None
P	Invalid position	No	Normal operation
E	Emergency manual override active	No	None
9	No communication with accessories	No	None
L	Battery voltage < 50 % (with installed fail-safe return unit)	No	Normal operation
i	Actuator was run in motor current limit	No	Stops

10.3 Troubleshooting

i **Repair the fault either while the supply voltage is still applied or when the actuator is briefly disconnected from the main power (not effective in cycle monitoring).**

1. Check the cause of fault. To do so, open the cover of the actuator, if necessary.
2. In order to remove the fault, press the SET button on the base board, in order to acknowledge the error, or disconnect the actuator from the mains.
3. Perform troubleshooting in accordance with the table.

Fault	Possible cause	Remedy
Actuator does not react	No power available	Check voltage source.
	Internal wiring error	Correct the wiring of the actuator, see Chapter 7 "Installation", Page 53.
	End positions not correctly set	Adjust the end positions, see Chapter 9.2 "Adjusting end positions", Page 61.
	Motor blocked	Use emergency manual override, see Chapter 9.1 "Insert the emergency manual override hand crank", Page 59.
Actuator only runs in one direction	Position sensor defective	Use emergency manual override, see Chapter 9.1 "Insert the emergency manual override hand crank", Page 59.
Overload protection is activated	Valve dirty/jammed	Clean the valve, see valve manual.
	Duty cycle too high	Extend cycle time with accessories "Cycle time extension".
	Ambient temperature too high	If possible, reduce ambient temperature.
Valve does not fully close or open	End positions not adjusted	Adjust the end positions, see Chapter 9.2 "Adjusting end positions", Page 61.
Valve does not close or open correctly	Valve stem twisted	Replace valve stem

i **If an end position is not reached, the actuator automatically switches off after 2 min. and displays a fault message.**

11 Maintenance



Lack of product quality through use of spare parts not provided by GF Piping Systems!

Danger of injury.

- ▶ Only use the listed spare parts, see Chapter 12 "Spare parts list", Page 68.

- ▶ Set maintenance intervals as per the conditions of use (e. g. actuating cycles, fluid, ambient temperature).
- ▶ As part of the regular system inspection, carry out the following maintenance activities:

Maintenance interval	Maintenance task
Regularly	<ul style="list-style-type: none"> ▶ Check that the cover of the emergency manual override is correctly installed. If necessary, install cover. ▶ Check that the housing cover of the actuator is secured with 4 screws. If necessary, tighten screws.
Regularly	<ul style="list-style-type: none"> ▶ Check if grating noises are coming from the actuator. Replace actuator, see assembly instructions for building valve with actuator.
Regularly	<ul style="list-style-type: none"> ▶ Check that position indicator matches signal of the control. ▶ If necessary, adjust the end positions, see Chapter 9.2 "Adjusting end positions", Page 61.

For questions regarding maintenance of the product, please contact your national GF Piping Systems representative.

12 Spare parts list

Designation	Code No.
Actuator EA25 100 – 230 V AC	198 153 182
Actuator EA25 24 V AC/DC	198 153 183
Actuator EA45 100 – 230 V AC	198 153 184
Actuator EA45 24 V AC/DC	198 153 185
Actuator EA120 100 – 230 V AC	198 153 186
Actuator EA120 24 V AC/DC	198 153 187
Actuator EA250 100 – 230 V AC	198 153 188
Actuator EA250 24 V AC/DC	198 153 189
Crank for emergency manual override	198 151 307
Manual emergency cover (lock screw)	198 000 503

13 Accessories

Designation	Function	Code No.
Fail-safe return unit with integrated battery pack	In case of a power outage, the fail-safe return unit can be used to move to a preset safe position (OPEN/CLOSE). Assembly in the housing actuator	199 190 601
External fail-safe return unit	In case of a power outage, the fail-safe return unit can be used to move to a preset safe position (OPEN/CLOSE). Voltage supply (24 V DC) implemented externally	199 190 604
Positioner	For continuous control operation (4-20 mA / 0-10 V)	199 190 603
Monitoring	For monitoring control time and motor current, as well as for extending the control times and counting the control cycles (even without bus system) via a collective alarm	199 190 602
Profibus	For integrating the actuator into a Profibus DP network	199 190 605
Diagnostic tool	For reading various data for a first error diagnosis via USB	199 190 600
AS-Interface module ASEV 2400	Connection to an AS-i network (supply in combination with limit switch kit)	199 190 562
Adapter SW 11 for F04	Modification for valves with F04 interface	198 000 587
Adapter SW 14 for F05	Modification for valves with F05 interface	198 204 057
Reducer bushing WS 11 for F05	Adjustment for valves with F05 interface and wrench size 11	198 803 145
Standard plug set	For the connection of accessories	198 000 502
Plug set 4 pin	For connection of MIDDLE position feedback	199 190 606

14 EC declaration of incorporation

EC Declaration of incorporation for incomplete machines (Machinery Directive 2006/42/EC Annex II B) and EC declaration of conformity as per EMV and low voltage directive (2004/108/EG), (2006/95/EG)

Manufacturer:

Georg Fischer Piping Systems Ltd., Ebnatstrasse 111, 8201 Schaffhausen / Switzerland

Person authorized to compile technical documentation:

Georg Fischer Piping Systems Ltd., R&D Manager, Ebnatstrasse 111, 8201 Schaffhausen / Switzerland

We hereby confirm that the following incomplete machine**Electrical actuator**

Type: EA25, EA45, EA120, EA250

Variants: 24V AC/DC, 100-230V AC

Article numbers: 198 153 182, 198 153 183, 198 153 184, 198 153 185, 198 153 186, 198 153 187, 198 153 188, 198 153 189

fulfils all the basic requirements of the machine directive 2006/42/EC, as far as the scope of delivery allows. We further declare that the special technical documentation has been compiled in accordance with Annex VII, Section B of this directive. We shall forward this, if requested, to the competent authorities via the aforementioned authorized person.

Commissioning is prohibited until it has been established that the entire machine, into which the aforementioned incomplete machine is to be incorporated, meets the provisions of the machine directive 2006/42/EC.

The incomplete machine also meets the requirements of the following European directives, implementing national legal provisions, and relevant harmonized standards:

- Electromagnetic compatibility – Directive EMV (2004/108/EG)
- Low voltage directive (2006/95/EG)
- EN 15714-2 (Electrical actuators for industrial valves)
- ISO 5211 (actuator interface)
- EN 60068-2-6 (vibration tests)
- VDE 0843 section 20 (EMV requirements)

Georg Fischer Piping Systems Ltd



Name: Antonio De Agostini

Position: R&D Manager

Georg Fischer Piping Systems Ltd

Date: 2016-01-11

15 Disposal

- ▶ Before disposal, separate the different materials into recyclable materials, normal waste, and special waste.
- ▶ Comply with the local regulations and legislation when recycling or disposing of the product, individual components, and packaging.
- ▶ Comply with national regulations, standards and guidelines.



Parts of the product may be contaminated with media that are harmful to health and the environment, so it is not enough just to clean them!

These media represent a risk of physical injury or damage to the environment.

Before disposing of the product:

- ▶ Collect leaking media and dispose of them according to local regulations. Refer to the safety data sheet.
- ▶ Neutralize any media residues remaining in the product.
- ▶ Separate the materials (plastics, metals etc.) and dispose of them according to local regulations.



Products marked with this symbol must be taken to a separate collection point for electrical and electronic devices.

If you have questions regarding the disposal of your product, please contact your national GF Piping Systems representative.

Worldwide at home

Our sales companies and representatives ensure local customer support in over 100 countries

www.gfps.com

Argentina / Southern South America

Georg Fischer Central Plastics
Sudamérica S.R.L.
Buenos Aires, Argentina
Phone +54 11 4512 02 90
gfcentral.ps.ar@georgfischer.com
www.gfps.com/ar

Australia

George Fischer Pty Ltd
Riverwood NSW 2210 Australia
Phone +61 (0) 2 9502 8000
australia.ps@georgfischer.com
www.gfps.com/au

Austria

Georg Fischer
Rohrleitungssysteme GmbH
3130 Herzogenburg
Phone +43 (0) 2782 856 43-0
austria.ps@georgfischer.com
www.gfps.com/at

Belgium / Luxembourg

Georg Fischer NV/SA
1070 Bruxelles/Brüssel
Phone +32 (0) 2 556 40 20
be.ps@georgfischer.com
www.gfps.com/be

Brazil

Georg Fischer Sist. de Tub. Ltda.
04571-020 São Paulo/SP
Phone +55 (0)11 5525 1311
br.ps@georgfischer.com
www.gfps.com/br

Canada

Georg Fischer Piping Systems Ltd
Mississauga, ON L5T 2B2
Phone +1 (905) 670 8005
Fax +1 (905) 670 8513
ca.ps@georgfischer.com
www.gfps.com/ca

China

Georg Fischer Piping Systems Ltd
Shanghai 201319
Phone +86 21 3899 3899
china.ps@georgfischer.com
www.gfps.com/cn

Denmark / Iceland

Georg Fischer A/S
2630 Taastrup
Phone +45 (0) 70 22 19 75
info.dk.ps@georgfischer.com
www.gfps.com/dk

Finland

Georg Fischer AB
01510 VANTAA
Phone +358 (0) 9 586 58 25
Fax +358 (0) 9 586 58 29
info.fi.ps@georgfischer.com
www.gfps.com/fi

France

Georg Fischer SAS
95932 Roissy Charles de Gaulle Cedex
Phone +33 (0) 1 41 84 68 84
fr.ps@georgfischer.com
www.gfps.com/fr

Germany

Georg Fischer GmbH
73095 Albershausen
Phone +49 (0) 7161 302-0
info.de.ps@georgfischer.com
www.gfps.com/de

India

Georg Fischer Piping Systems Ltd
400 083 Mumbai
Phone +91 224007 2001
branchoffice@georgfischer.com
www.gfps.com/in

Indonesia

George Fischer Pte Ltd –
Representative Office
Phone +62 21 2900 8564
Fax +62 21 2900 8566
sgp.ps@georgfischer.com
www.gfps.com/sg

Italy

Georg Fischer S.p.A.
20063 Cernusco S/N (MI)
Phone +39 02 921 861
it.ps@georgfischer.com
www.gfps.com/it

Japan

Georg Fischer Ltd
556-0011 Osaka,
Phone +81 (0) 6 6635 2691
jp.ps@georgfischer.com
www.gfps.com/jp

Korea

GF Piping Systems
Georg Fischer Korea Co., Ltd.
Unit 2501, U-Tower
120 HeungdeokJungang-ro (Yeongdeok-dong)
Giheung-gu, Yongin-si, Gyeonggi-do, Korea
Phone: +82 31 8017 1450
Fax: +82 31 217 1454
kor.ps@georgfischer.com
www.gfps.com/kr

Malaysia

Georg Fischer (M) Sdn. Bhd.
40460 Shah Alam, Selangor Darul Ehsan
Phone +60 (0) 3 5122 5585
Fax +603 5122 5575
my.ps@georgfischer.com
www.gfps.com/my

Mexico / Northern Latin America

Georg Fischer S.A. de C.V.
Apodaca, Nuevo Leon
CP66636 Mexico
Phone +52 (81) 1340 8586
Fax +52 (81) 1522 8906
mx.ps@georgfischer.com
www.gfps.com/mx

Middle East

Georg Fischer
Piping Systems (Switzerland) Ltd
Dubai, United Arab Emirates
Phone +971 4 289 49 60
gcc.ps@georgfischer.com
www.gfps.com/int

Netherlands

Georg Fischer N.V.
8161 PA Epe
Phone +31 (0) 578 678 222
nl.ps@georgfischer.com
www.gfps.com/nl

Norway

Georg Fischer AS
1351 Rud
Phone +47 67 18 29 00
no.ps@georgfischer.com
www.gfps.com/no

Philippines

Georg Fischer Pte Ltd
Representative Office
Phone +632 571 2365
Fax +632 571 2368
sgp.ps@georgfischer.com
www.gfps.com/sg

Poland

Georg Fischer Sp. z o.o.
05-090 Sekocin Nowy
Phone +48 (0) 22 31 31 0 50
poland.ps@georgfischer.com
www.gfps.com/pl

Romania

Georg Fischer
Piping Systems (Switzerland) Ltd
020257 Bucharest - Sector 2
Phone +40 (0) 21 230 53 80
ro.ps@georgfischer.com
www.gfps.com/int

Russia

Georg Fischer
Piping Systems (Switzerland) Ltd
Moscow 125040
Phone +7 495 748 11 44
ru.ps@georgfischer.com
www.gfps.com/ru

Singapore

George Fischer Pte Ltd
11 Tampines Street 92, #04-01/07
528 872 Singapore
Phone +65 6747 0611
Fax +65 6747 0577
sgp.ps@georgfischer.com
www.gfps.com/sg

Spain / Portugal

Georg Fischer S.A.
28046 Madrid
Phone +34 (0) 91 781 98 90
es.ps@georgfischer.com
www.gfps.com/es

Sweden

Georg Fischer AB
117 43 Stockholm
Phone +46 (0) 8 506 775 00
info.se.ps@georgfischer.com
www.gfps.com/se

Switzerland

Georg Fischer
Rohrleitungssysteme (Schweiz) AG
8201 Schaffhausen
Phone +41 (0) 52 631 30 26
ch.ps@georgfischer.com
www.gfps.com/ch

Taiwan

Georg Fischer Co., Ltd
San Chung Dist., New Taipei City
Phone +886 2 8512 2822
Fax +886 2 8512 2823
www.gfps.com/tw

United Kingdom / Ireland

Georg Fischer Sales Limited
Coventry, CV2 2ST
Phone +44 (0) 2476 535 535
uk.ps@georgfischer.com
www.gfps.com/uk

USA / Caribbean

Georg Fischer LLC
9271 Jeronimo Road
92618 Irvine, CA
Phone +1 714 731 88 00
Fax +1 714 731 62 01
us.ps@georgfischer.com
www.gfps.com/us

International

Georg Fischer
Piping Systems (Switzerland) Ltd
8201 Schaffhausen/Switzerland
Phone +41 (0) 52 631 30 03
Fax +41 (0) 52 631 28 93
info.export@georgfischer.com
www.gfps.com/int

The technical data are not binding. They neither constitute expressly warranted characteristics nor guaranteed properties nor a guaranteed durability. They are subject to modification. Our General Terms of Sale apply.