

Rosemount™ 396P/396PVP

pH/ORP Sensors



Essential Instructions

Read this page before proceeding

Emerson designs, manufactures and tests its products to meet many national and international standards. Because these sensors are sophisticated technical products, you **MUST** properly install, use, and maintain them to ensure they continue to operate within their normal specifications. The following instructions **MUST** be adhered to and integrated into your safety program when installing, using, and maintaining Rosemount products. Failure to follow the proper instructions may cause any one of the following situations to occur: Loss of life; personal injury; property damage; damage to this sensor; and warranty invalidation.

- Read all instructions prior to installing, operating, and servicing the product.
- If you do not understand any of the instructions, contact your Emerson representative for clarification.
- Follow all warnings, cautions, and instructions marked on and supplied with the product.
- Inform and educate your personnel in the proper installation, operation, and maintenance of the product.
- Install your equipment as specified in the Installation Instructions of the appropriate Reference Manual and per applicable local and national codes. Connect all products to the proper electrical and pressure sources.
- To ensure proper performance, use qualified personnel to install, operate, update, program, and maintain the product.
- When replacement parts are required, ensure that qualified people use replacement parts specified by Emerson. Unauthorized parts and procedures can affect the product's performance, place the safe operation of your process at risk, and **VOID YOUR WARRANTY**. Third-party substitutions may result in fire, electrical hazards, or improper operation.
- Ensure that all equipment doors are closed and protective covers are in place, except when maintenance is being performed by qualified persons, to prevent electrical shock and personal injury.

The information contained in this document is subject to change without notice.



DANGER

Hazardous Area Installation

Installations near flammable liquids or in hazardous area locations must be carefully evaluated by qualified on site safety personnel.

To secure and maintain an intrinsically safe installation, the certified safety barrier, transmitter, and sensor combination must be used. The installation system must comply with the governing approval agency (FM, CSA or BASEEFA/CENELEC) hazardous area classification requirements. Consult your transmitter Reference Manual for more details.

Proper installation, operation and servicing of this sensor in a Hazardous Area Installation is entirely the responsibility of the user.



CAUTION

Sensor/Process Application Compatibility

The wetted sensor materials may not be compatible with process composition and operating conditions. Application compatibility is entirely the responsibility of the user.



CAUTION

Special Conditions for Safe Use

1. All pH/ORP sensors have a plastic enclosure which must only be cleaned with a damp cloth to avoid the danger due to a build up of an electrostatic charge.
2. All pH/ORP sensor models are intended to be in contact with the process fluid and may not meet the 500V r.m.s. a.c. test to earth.

This must be taken into consideration at installation.

Contents

Section 1: Description and Specifications

1.1 Features and Applications	1
1.2 Product Certifications	2
1.3 Ordering Information.....	3

Section 2: Installation

2.1 Unpacking and Inspection	7
2.2 Mounting	7

Section 3: Wiring

3.1 General	13
-------------------	----

Section 4: Start-Up and Calibration

4.1 Rosemount 396P and 396PVP pH Sensors.....	35
4.2 Rosemount 396P and 396PVP ORP Sensors.....	36

Section 5: Maintenance

5.1 General Information.....	37
5.2 Automatic Temperature Compensator	37
5.3 Rosemount 396P and 396PVP pH Sensors.....	37
5.4 Rosemount 396P and 396PVP ORP Sensors.....	38

Section 6: Diagnostics and Troubleshooting

6.1 56/1056/1057/1066/54e/81/3081/4081/5081/Xmt Diagnostics and Troubleshooting.....	41
6.2 Troubleshooting without Advanced Diagnostics	42

EC Declaration of Conformity

Intrinsically Safe Sensor Installation - FM

Section 7: Return of Material

7.1 General.....	49
------------------	----

Section 1: Description and Specifications

1.1 Specifications - General

Measurements and Ranges: pH*: 0-14 / ORP: -1500 to 1500 mv

Available pH ACCUGLASS Types: GPLR hemi or flat glass

Wetted Materials: Titanium, Polypropylene, EPDM, glass; platinum (ORP only)

Process Connection: 1 in. MNPT front and rear facing threads

Temperature Range: 0-100°C (32-212°F)

Pressure Range-Hemi bulb: 100-1135 kPa [abs] (0-150 psig)

Pressure Range-Flat bulb: 100-790 kPa [abs] (0-100 psig)

Minimum Conductivity: 100 µS/cm

Integral Cable 396P: Code 01 - 25 ft; Code 02 - 15 ft coaxial / 396PVP: none - must use mating VP cable

Weight/Shipping Weight: 0.45 kg/0.9 kg (1 lb/2 lb)

*Percent Linearity

pH Range	396 / 396VP		396P / 396PVP		396R / 396RVP	
	GPHT Hemi	GPHT Flat	GPHT Hemi	GPLR Flat	GPHT Hemi	GPHT Flat
0-2 pH	94%	95%	94%	-	94%	93%
2-12 pH	99%	99%	97%	98%	97%	98%
12-13 pH	97%	96%	98%	95%	98%	95%
13-14 pH	92%	-	98%	-	98%	-

1.2 Product Certifications

See online certificates for more details

IECEX

See online certificates for more details.



Sensors without preamp (pH and ORP) – Ex ia IIC T4 Ga (-20 °C ≤ Ta ≤ +60 °C)

Sensors with SMART preamp (pH only) – Ex ia IIC T4 Ga (-20 °C ≤ Ta ≤ +60 °C)

Sensors with standard preamp (396P only) – Ex ia IIC T4 Ga (-20 °C ≤ Ta ≤ +80 °C) or
Ex ia IIC T5 Ga (-20 °C ≤ Ta ≤ +40 °C)

Per standards IEC60079-0 : 2011, IEC 60079-11 : 2011

ATEX

Sensors without preamp (pH and ORP) –  II 1 G Ex ia IIC T4 Ga (-20 °C ≤ Ta ≤ +60 °C)

Sensors with SMART preamp (pH only) –  II 1 G Ex ia IIC T4 Ga (-20 °C ≤ Ta ≤ +60 °C)

Sensors with standard preamp (396P only) –  II 1 G Ex ia IIC T4 Ga (-20 °C ≤ Ta ≤ +80 °C) or
 II 1 G Ex ia IIC T5 Ga (-20 °C ≤ Ta ≤ +40 °C)

Per standards EN 60079-0: 2012+A11:2013, EN 60079-11:2012

FM

See online FM Certificate of Compliance for applicable sensor options.



Intrinsically Safe for use in Class I, II, and III, Division 1, Groups A, B, C, D, E, F, and G;
Temperature Class T6 Ta = -20 °C to +60 °C

Intrinsically Safe for use in Class I, Zone 0, AEx ia IIC T6 Ta = -20 °C to +60 °C

Nonincendive for use in Class I, Division 2, Groups A, B, C, and D;
Temperature Class T6 Ta = -20 °C to +60 °C

Suitable for use in Class II and III, Division 2, Groups E, F, and G;
Temperature Class T6 Ta = -20 °C to +60 °C Hazardous (Classified) Locations

IS/I,II,III/1/ABCDEFG/T6 Ta = 60 °C - 1400332; Entity; I/0/AEx ia IIC/T6 Ta = 60 °C - 1400332;
Entity; NI/I/2/ABCD/T6 Ta = 60 °C; S/II,III/2/EFG/T6 Ta = 60 °C

Per standards 3600:1998, 3610:2010, 3611:2004, 3810:2005

CSA

See online CSA Certificate of Compliance for applicable sensor options.



Sensors with preamp – Intrinsically Safe:

Class I, Division 1, Groups ABCD; Class II, Division 1, Groups EFG; Class III; Class I, Division 2,
Groups ABCD; Ambient temperature rating -20 °C to +60 °C; Ex ia IIC; T6

Sensors without preamp – Intrinsically Safe and Non-Incendive:

Class I, Division 1, Groups ABCD; Class II, Division 1, Groups EFG; Class III; Class I, Division 2,
Groups ABCD; Ex ia IIC; T6; Ambient temperature rating -20 °C to +60 °C: (Simple Apparatus)

Per standards C22.2 No. 0-10, C22.2 No. 0.4-M2004, C22.2 No. 94-M1991, C22.2 No. 142 –
M198, C22.2 No 157 – M1992, CAN/CSA E60079-0:0, CAN/CSA E60079-11:02, UL50 11th Ed,
UL508 17th Ed, UL913 7th Ed, UL 60079-0: 2005, UL 60079-11: 2002

1.3 Ordering Information

The Rosemount 396P Sensor is housed in a molded reinforced polypropylene body with 1 in. MNPT threads suitable for insertion, submersion or flow through installation. The sensor includes a general purpose pH electrode or a platinum ORP electrode, a reference junction and a solution ground. The Rosemount 396P comes standard with a recessed electrode; an optional slotted tip is also available. In addition, the Rosemount 396P features an optional integral hermetically sealed preamplifier and 15 ft or 25 ft cable lengths. Automatic temperature compensation, Pt 100 or 3K Balco, is standard with the Rosemount 396P.



Rosemount 396P with Integral Cable Connection



Rosemount 396PVP with Variopol Cable Connection

The Rosemount 396PVP Sensor has similar features to the Rosemount 396P. However, the Rosemount 396PVP is offered with the Variopol (VP) connector and uses a mating VP cable (purchased separately).

A Variopol cable is required for all new installations. See below for cable selection.



Variopol connector shown with mating variopol cable receptacle

Examples of all sensing tip offerings



Shrouded Tip is standard on all hemi bulb sensors



Optional Slotted Tip is available on all hemi bulb sensors, ordered as option -41



Flat Tip is available with flat glass bulb sensors

Table 1-1. Rosemount 396P Ordering Information

Model	Sensor Type
396P	pH/ORP Sensor
Preamplifier/Cable	
01	With Integral Preamplifier and 25 ft (7.6m) Cable
02	Without Integral Preamplifier and 15 ft (4.6m) Cable
Measuring Electrode Type	
10	pH - GPLR Glass
12	ORP
13	pH - GPLR Flat Glass
Transmitter/TC Compatibility	
50	For 1181 (3K TC)
54	For 1054A/B, 2054 2081 (Pt-100)
55	For 54, 1055, 1056, 1057, 6081, 3081, 4081, 5081, XMT, 56 (Pt-100)
Optional Tip Offerings	
_	No Selection
41	Slotted Tip ⁽¹⁾
Typical Model Number: 396P-01-10-55	

1. Not available with option 13.

Table 1-1. Rosemount 396PVP Ordering Information

Model	Sensor Type
396PVP	pH/ORP Sensor
Measuring Electrode Type	
10	pH - GPLR Glass
12	ORP
13	pH - GPLR Flat Glass
Transmitter/TC Compatibility	
50	For 1181 (3K TC)
54	For 1054A/B, 2054 2081 (Pt-100)
55	For 54, 1055, 1056, 1057, 6081, 3081, 4081, 5081, XMT, 56 (Pt-100)
Optional Tip Offerings	
_	No Selection
41	Slotted Tip ⁽¹⁾
Preamplifier Option	
_	No Preamplifier
70	SMART Preamplifier ⁽²⁾
Typical Model Number: 396PVP-10-55-_-70	

1. Not available with option 13.
2. Only available with pH sensors and option 55.

Accessories

Table 1-3. Accessories Information

Connector cable, VP8 (required for all first time installations of VP sensors)	
24281-00	15 ft. (4.6m) VP8 cable
24281-01	25 ft. (7.6m) VP8 cable
24281-03	50ft (15.2m) VP8 Cable
24281-04	100ft (30.5m) VP8 Cable
24281-06	10ft (3.0m) VP8 Cable
24281-07	20ft (6.1m) VP8 Cable
24281-08	30ft (9.1m) VP8 Cable
Remote Junction Boxes and Mounting Brackets; for use when standard cable lengths need to be extended	
23555-00	Junction Box; contains preamplifier for 54e, 56, 1055, 1056, 1057, 1066, 3081, 4081, 5081, 6081, XMT
23550-00	Junction Box with board for point-to-point cable extension; use with sensors containing integral preamplifiers
2002565	Mounting Bracket Kit with mounting plate and U-bolts; use with PN 23555-00 or 23550-00 junction boxes
Extension Cables (required when using a remote junction box)	
23646-01	Extension Cable, 11-conduit with shields, wires prepared for easy installation, per foot (or meter); best choice for easiest installation
9200273	Extension Cable, 11-conduit with shield, raw cable (user must cut and prepare cable ends), per foot (or meter)
Calibration Accessories	
9210012	Buffer Solution, pH 4.01, 16 oz (473 ml)
9210013	Buffer Solution, pH 6.86, 16 oz (473 ml)
9210014	Buffer Solution, pH 9.18, 16 oz (473 ml)
R508-8OZ	ORP Standard, 475mV, 8oz (236 ml)
Mounting Assemblies	
11275-01	Handrail Mounting Assembly; includes a 6 ft straight pipe, pipe coupling, 6 ft long sweep pipe, unistrut, pipe clamps, and mounting channels
2002011	CPVC flow through Tee, 1-1/2 in. NPT process connections
24091-00	Low Flow Cell with 1/4 in. inlet and outlet
915240-03	Tee, Flow-through, 2 in. PVC tee with 3/4 in. NPT process connections and mounting adapter to eliminate cable twisting
915240-04	Tee, Flow-through, 2 in. PVC tee with 1 in. NPT process connections and mounting adapter to eliminate cable twisting
915240-05	Tee, Flow-through, 2 in. PVC tee with 1 1/2 in. NPT process connections and mounting adapter to eliminate cable twisting
12707-00	Jet Spray Cleaner; for use with water or air cleaning using interval timer from instrument

Section 2: Installation

2.1 Unpacking and Inspection

Inspect the outside of the carton for any damage. If damage is detected, contact the carrier immediately. Inspect the hardware. Make sure all the items in the packing list are present and in good condition. Notify the factory if any part is missing. If the sensor appears to be in satisfactory condition, proceed to Section 2.2, Mounting.

NOTE: Save the original packing cartons and materials as most carriers require proof of damage due to mishandling, etc. Also, if it is necessary to return the sensor to the factory, you must pack the sensor in the same manner as it was received. Refer to Section 6.0 for return instructions. If the sensor is to be stored, the vinyl boot should be filled with pH buffer solution and replaced on sensor tip until ready to use.



CAUTION

Buffer solution, in the vinyl boot, may cause skin or eye irritation.



WARNING

Glass electrode must be wetted at all times (in storage and in line) to maximize sensor life.

2.2 Mounting

The sensor has been designed to be located in industrial process environments. Temperature and pressure limitations must not be exceeded at any time. A caution label regarding this matter is attached to the sensor. Please do not remove the label. See Figure 2-1.



CAUTION

Internal electrolyte fill solution may cause skin or eye irritation.

Mounting Guidelines:

1. Shake the sensor in a downward motion to remove any air bubbles that may be present inside the tip of the pH glass.
2. Do not install the sensor on the horizontal. The sensor must be 10° off the horizontal to ensure accuracy.
3. Do not install the sensor upside down.
4. Air bubbles may become trapped in the sensor end between the glass bulb and the sensor body. This problem is most commonly encountered in areas of low flow or during calibration. Shake the probe while immersed in solution to remove bubbles. This problem can be avoided by ordering the sensor with the slotted tip (option 41).

In most cases, the pH sensor can simply be installed as shipped and readings with an accuracy of ± 0.6 pH may be obtained. To obtain greater accuracy or to verify proper operation, the sensor must be calibrated as a loop with its compatible analyzer or transmitter.

2.2.1 Flow Through and Insertion Mounting

Rosemount 396P and 396PVP Sensors have a 1-inch MNPT process connection at the front of the sensor for mounting into a 1-1/2 inch tee or the process pipes. See Figure 2-2 through Figure 2-7 for installation configurations.

NOTE: LARGE PIPE WRENCHES MUST NOT BE USED TO TIGHTEN THE SENSOR INTO A FLANGE OR OTHER TYPE OF MOUNTING.

2.2.2 Submersion Mounting

Rosemount 396P and 396PVP Sensors also have a 1 inch MNPT process connection at the back of the sensor. Utilizing a standard 1 inch union, the sensor may be mounted to a 1 inch SCH 80 CPVC or PVDF standpipe. Tapered pipe threads in plastic tend to loosen after installation. It is therefore recommended that Teflon1 tape be used on the threads and that the tightness of the connection be checked frequently to assure that no loosening has occurred. To prevent rain water or condensation from running into the sensor, a weatherproof junction box is recommended. The sensor cable must be run through a protective conduit for isolation from electrical interference or physical abuse from the process. The sensor should be installed within 80° of vertical, with the electrode facing down. The sensor's cable should not be run with power or control wiring.

Figure 2-1. Dimensional Drawing

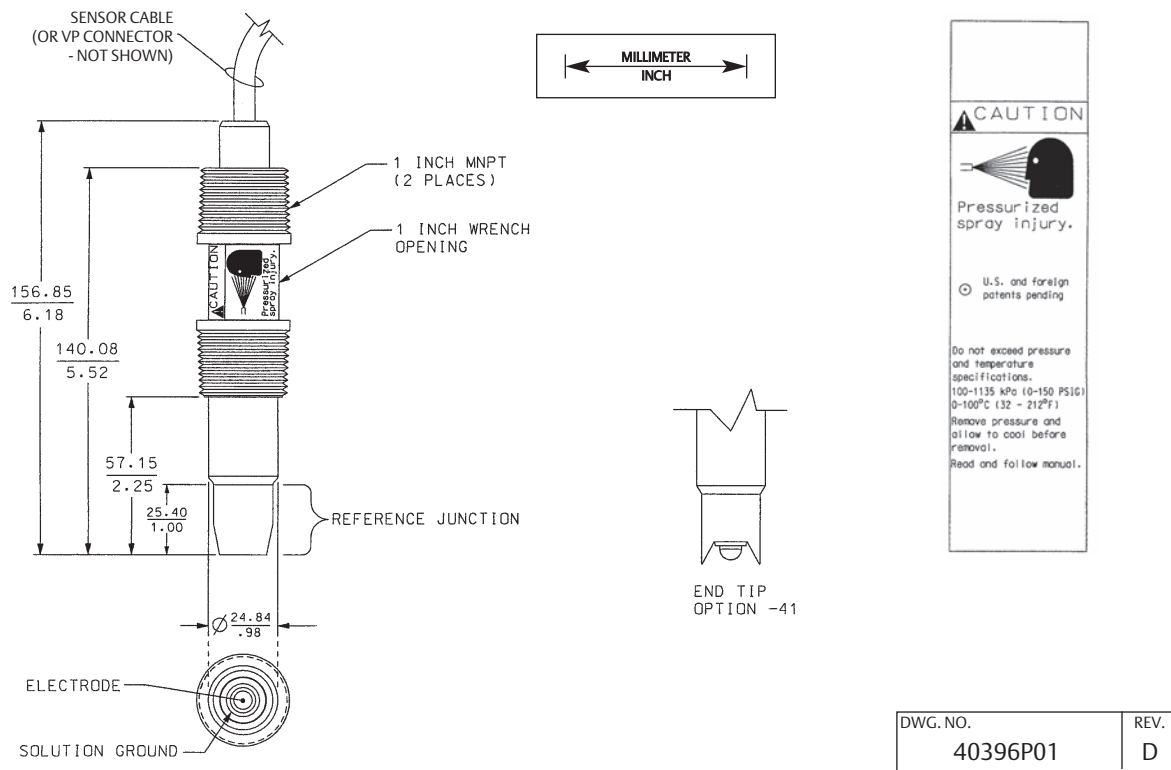

Figure 2-2. Flow-Through Tee with Adapter (PN 915240-xx*)

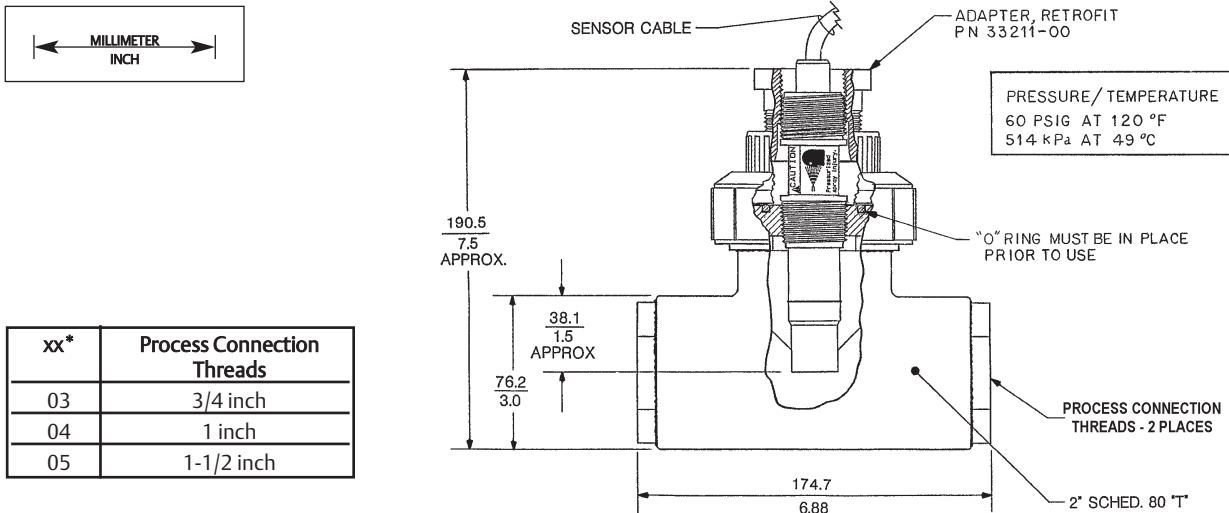
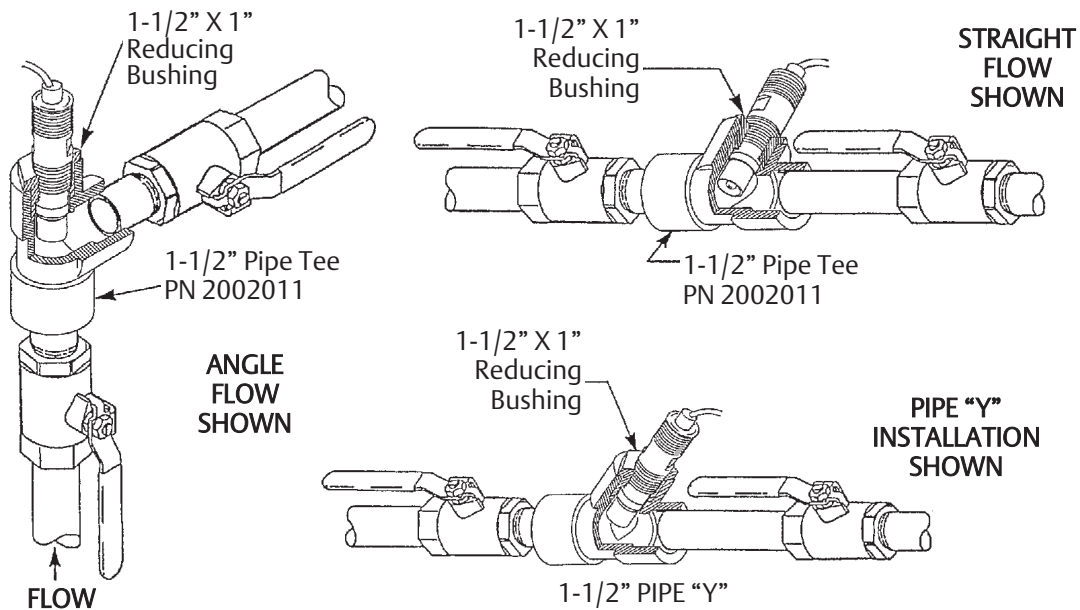

Figure 2-3. Flow-Through and Insertion Installations



WHEN INCH AND METRIC DIMS
ARE GIVEN

MILLIMETER
INCH

Figure 2-4. Rosemount 396P with Insertion Mounting Adapter (PN 23242-02). Not for use with Rosemount 396PVP. Mounting adapter allows for sensor removal without twisting or disconnecting interconnecting cable for ease of maintenance.

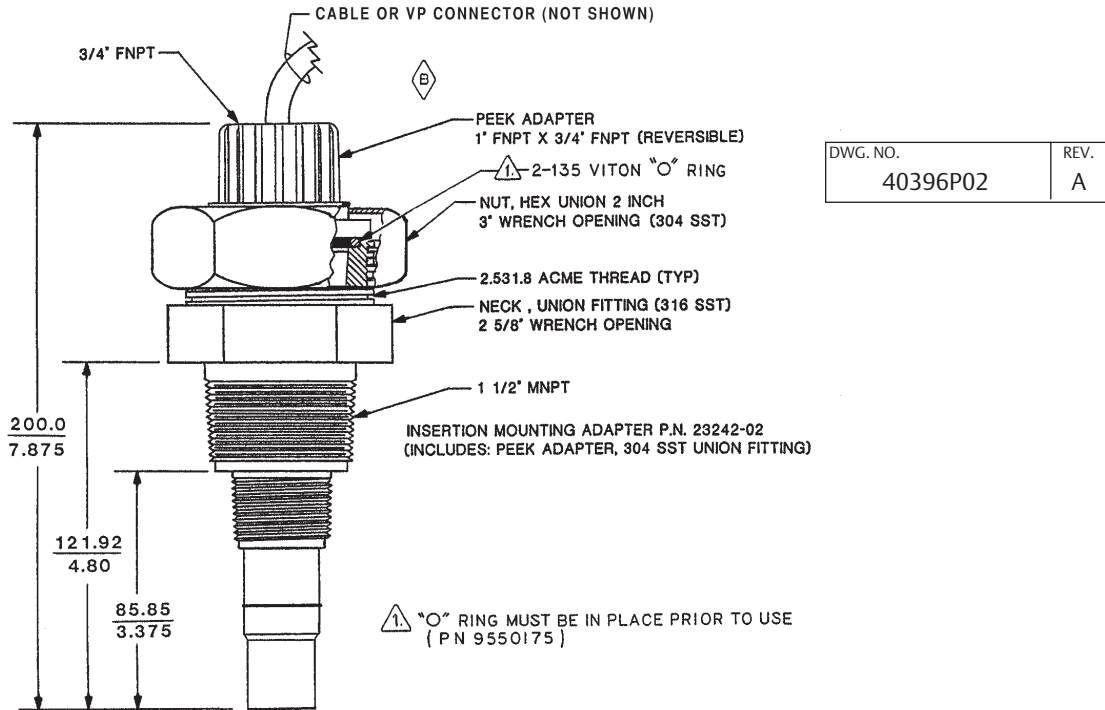

Figure 2-5. Low flow cell PN 24091-00

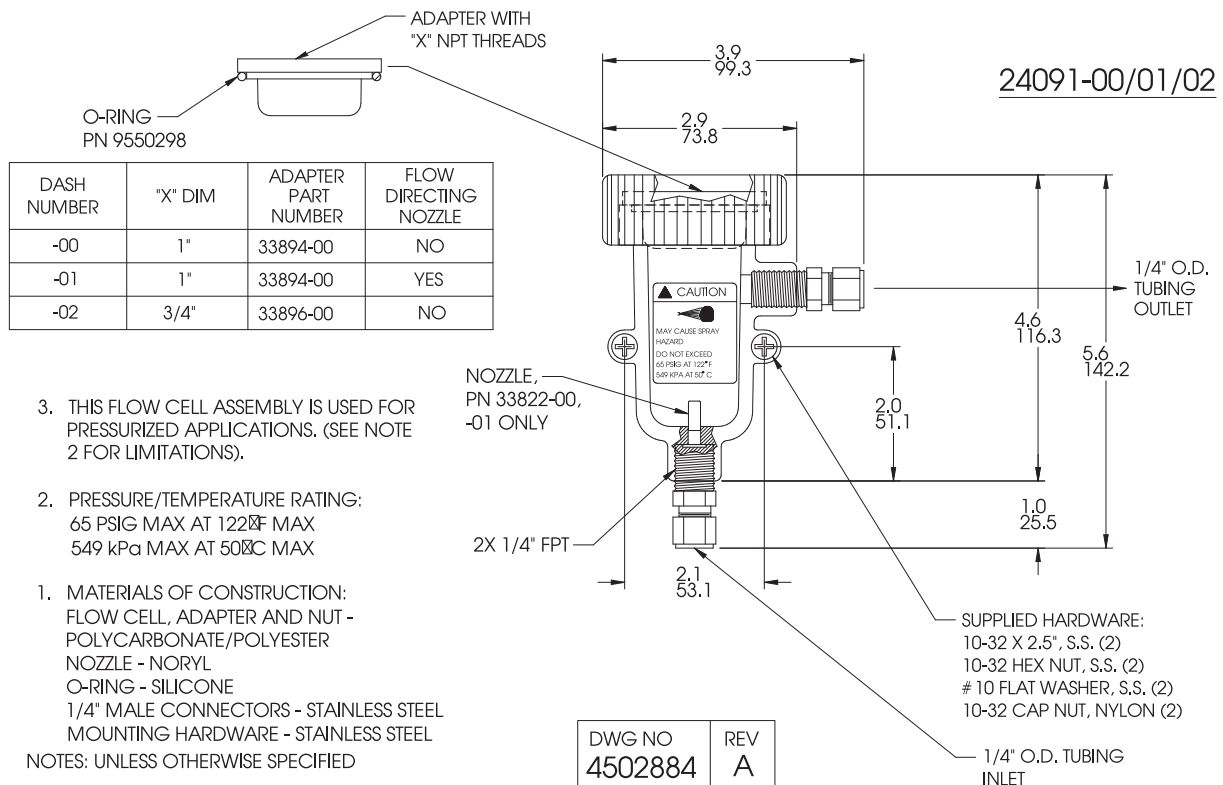

Figure 2-6. Submersion Installations

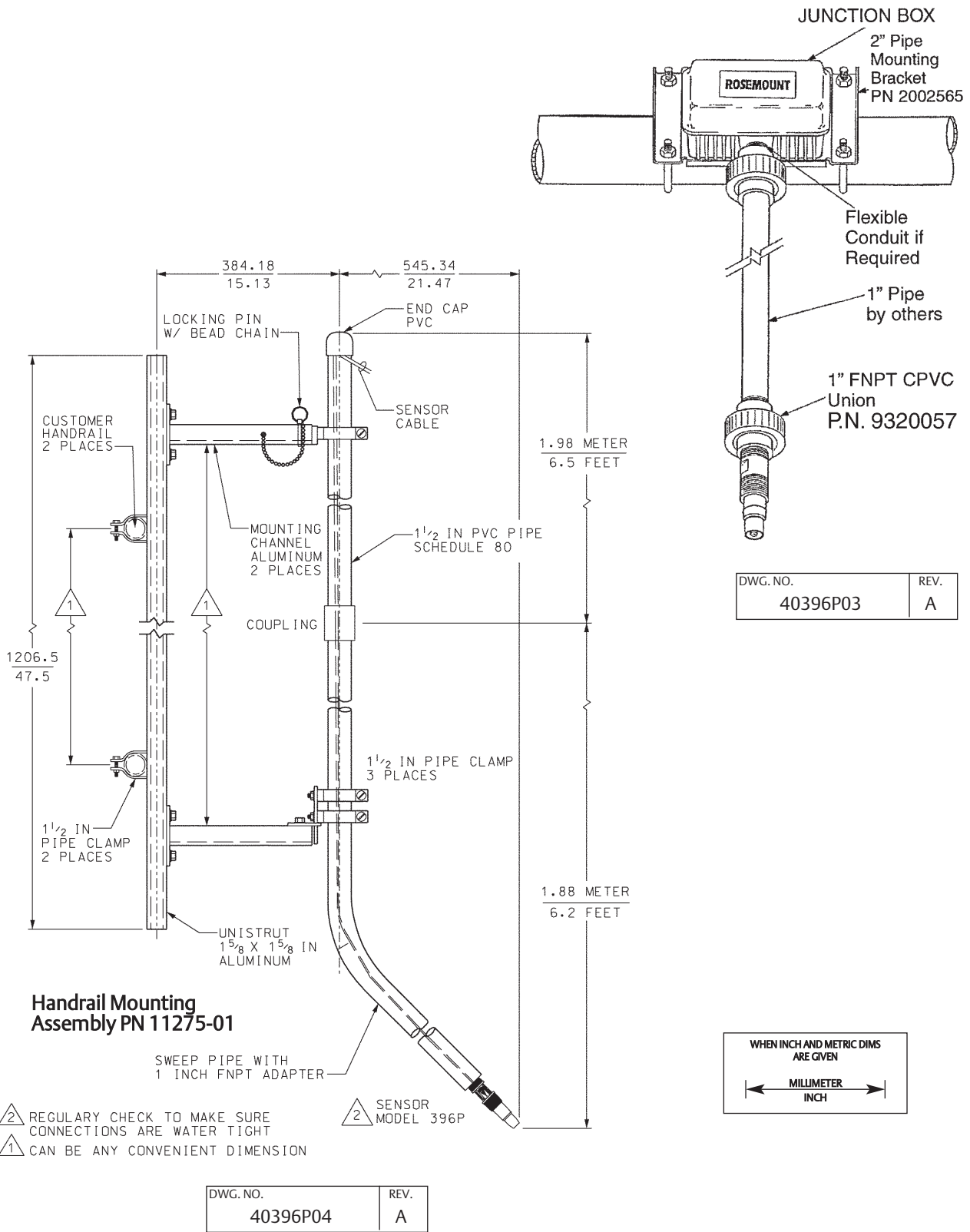
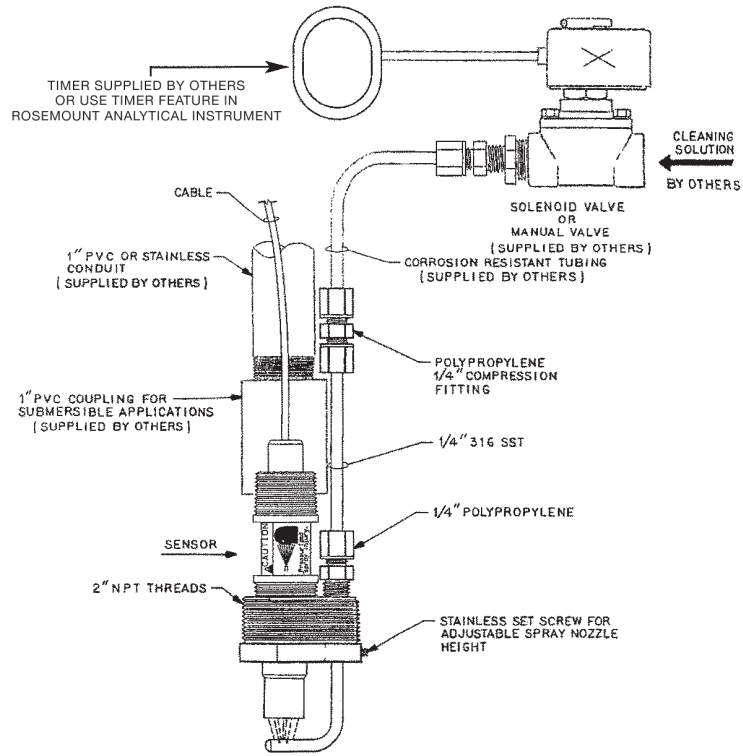

Figure 2-7. Jet Spray Cleaner PN 12707-00



Section 3: Wiring

3.1 General

Figures in this section provide guidelines for wiring the Rosemount 396P/396PVP sensor to various transmitters.

To determine which wiring guideline to use, locate the model number of the sensor to be installed.

1. If the cable needs to be extended, use a high quality eleven conductor double shielded instrument cable available from Rosemount. Refer to Table 3-1 for the appropriate junction box to use and the corresponding wiring details.

NOTE: If the cable is too long, loop up the excess cable. If the cable has to be shortened, cut and terminate each conductor neatly and make sure that the overall (outermost) drain wire is not shorted out with either of the two inner drain wires (shields).

2. Signal cable should be run in a dedicated conduit (preferably an earth grounded metallic conduit) and should be kept away from AC power lines. For your convenience, a wire nut kit is furnished (in a plastic bag wrapped around the cable).

NOTE: For maximum EMI/RFI protection when wiring from the sensor to the junction box, the outer braid of the sensor should be connected to the outer braided shield of the extension cable. The outer braid of the extension cable to the instrument must be terminated at earth ground or by using an appropriate metal cable gland fitting that provides a secure connection to the instrument cable.

Wiring

The Rosemount 396P and 396PVP has an optional built-in preamplifier and is offered with a shielded cable. The cable should be handled carefully and kept dry and free of corrosive chemicals at all times. Extreme care should be used to prevent it from being twisted, damaged or scraped by rough, sharp edges or surfaces.



DO NOT CONNECT SENSOR CABLE TO POWER LINES. SERIOUS INJURY MAY RESULT.

NOTE: Remove electrical tape or shrink sleeve from gray reference wire before connecting wire to terminal.

NOTE

For additional wiring information on this product, including sensor combinations not shown here, please refer to our website [Wiring Diagrams](#).

Figure 3-1. Wiring for 396P-01 (Gray Cable) and 54e pH/ORP

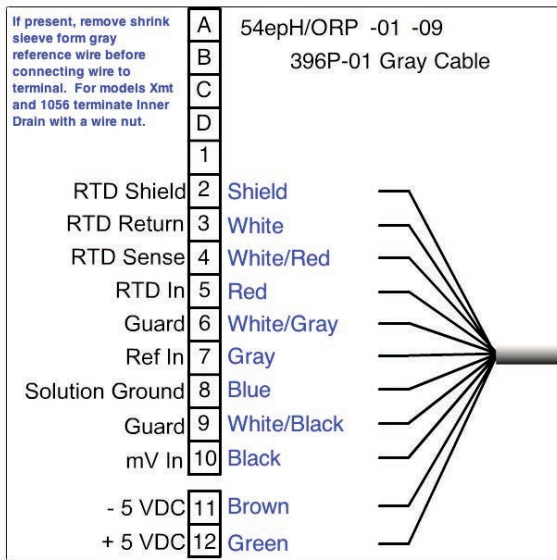

Figure 3-2. Wiring for 396P-01 (Blue Cable) and 54e pH/ORP

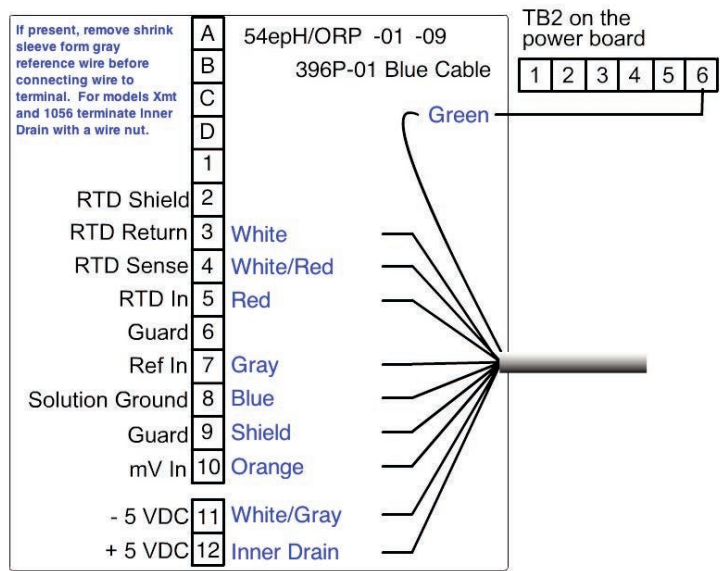

Figure 3-3. Wiring for 396P-02 (Gray Cable) and 54e pH/ORP

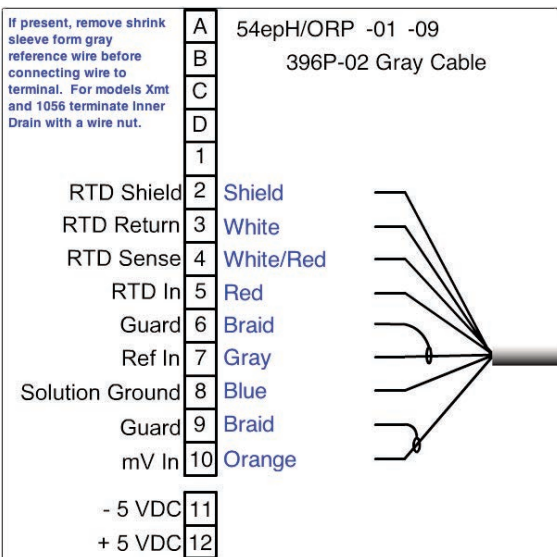

Figure 3-4. Wiring for 396P-02 (Blue Cable) and 54e pH/ORP

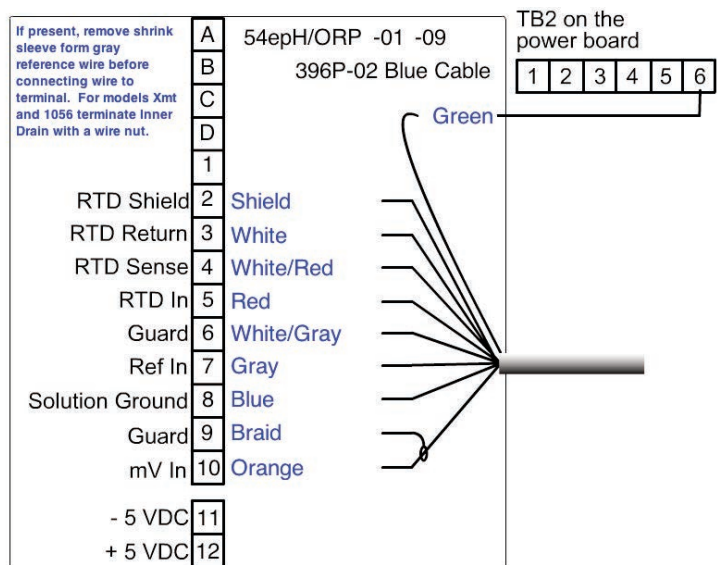

Figure 3-5. Wiring for 396PVP (Gray Cable) and 54e pH/ORP

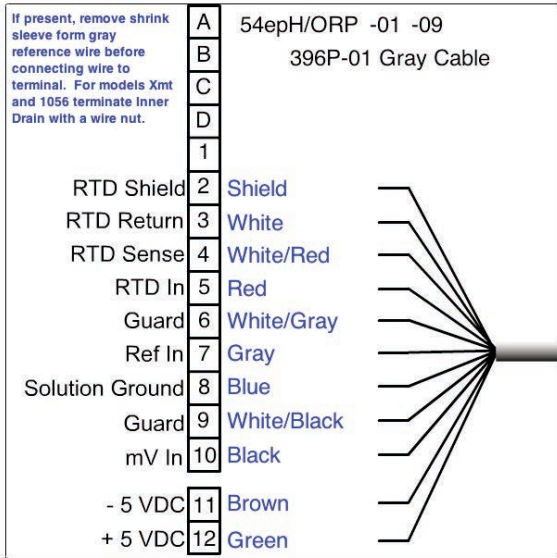

Figure 3-6. Wiring for 396PVP (Blue Cable) and 54e pH/ORP

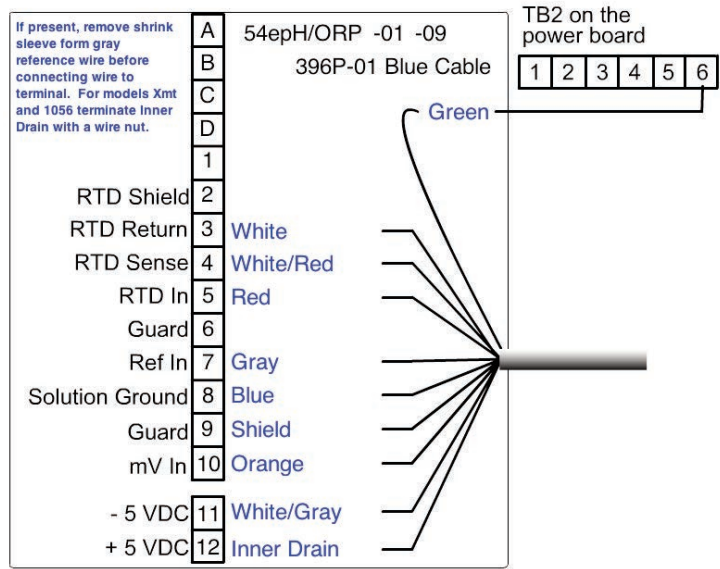

Figure 3-7. Wiring for 396P-01 and 1055

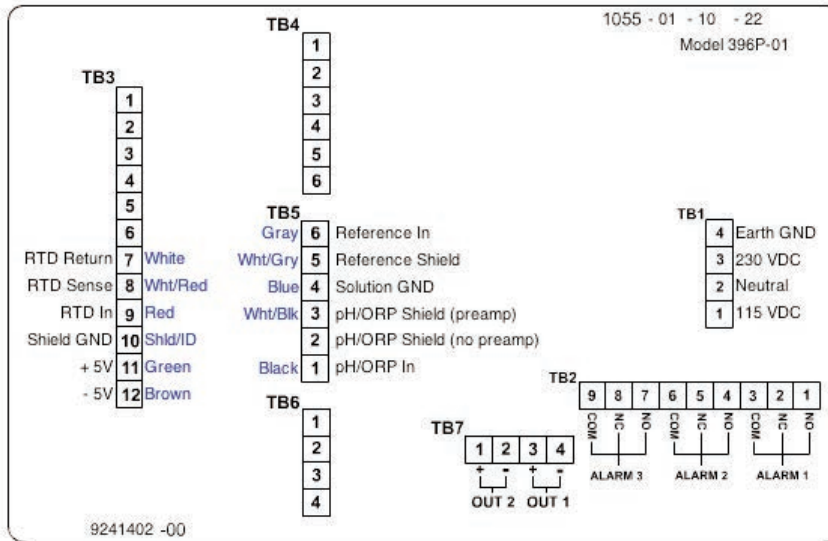

Figure 3-8. Wiring for 396P-02 and 1055

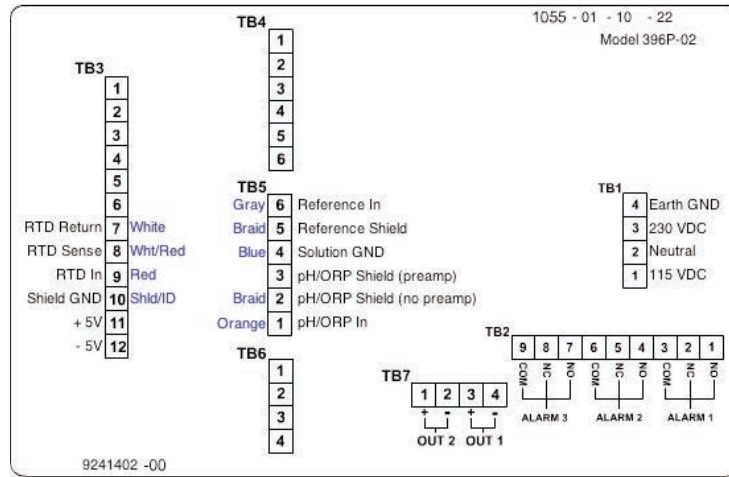

Figure 3-9. Wiring for 396PVP and 1055

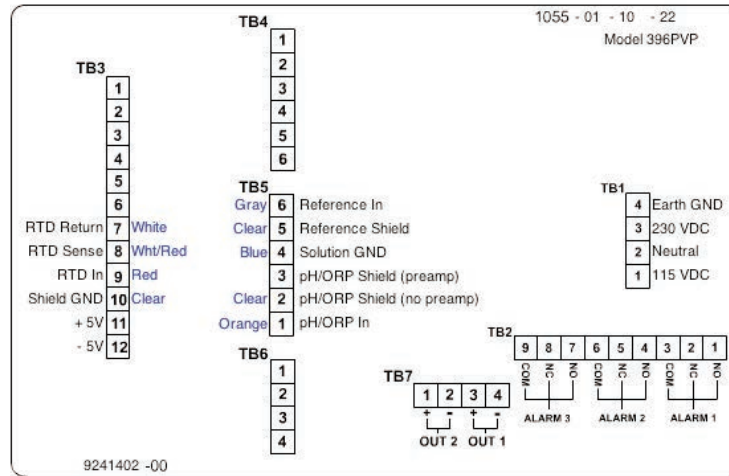

Figure 3-10. Wiring for Dual 396P-01 and 1055

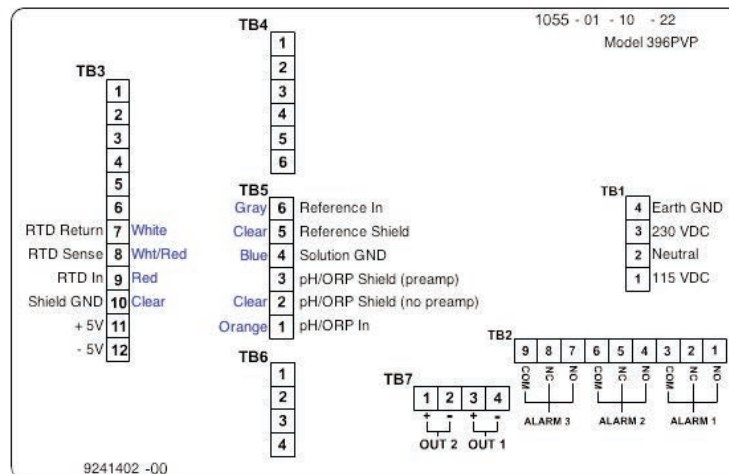

Figure 3-11. Wiring for Dual 396P-02 and 1055

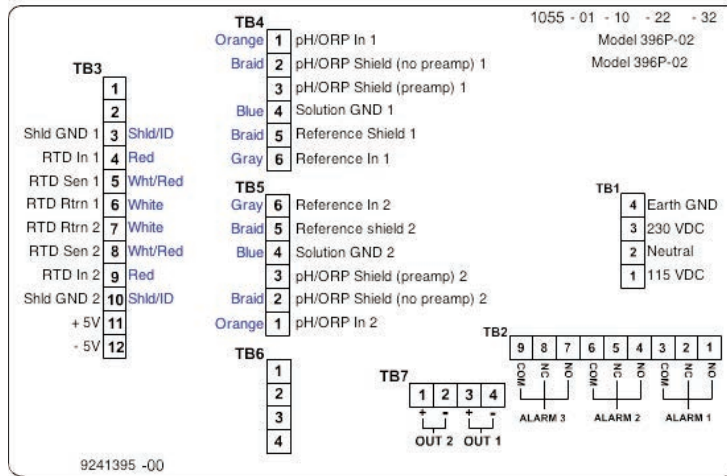

Figure 3-12. Wiring for Dual 396PVP and 1055

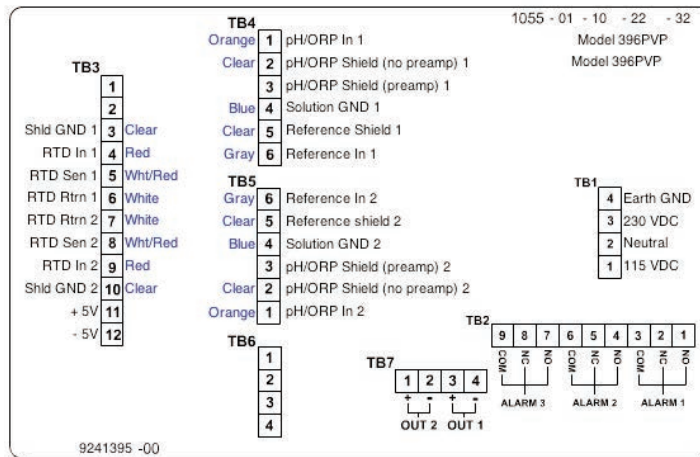

Figure 3-13. Wiring for 396P-01 (Gray Cable) and 1056/56

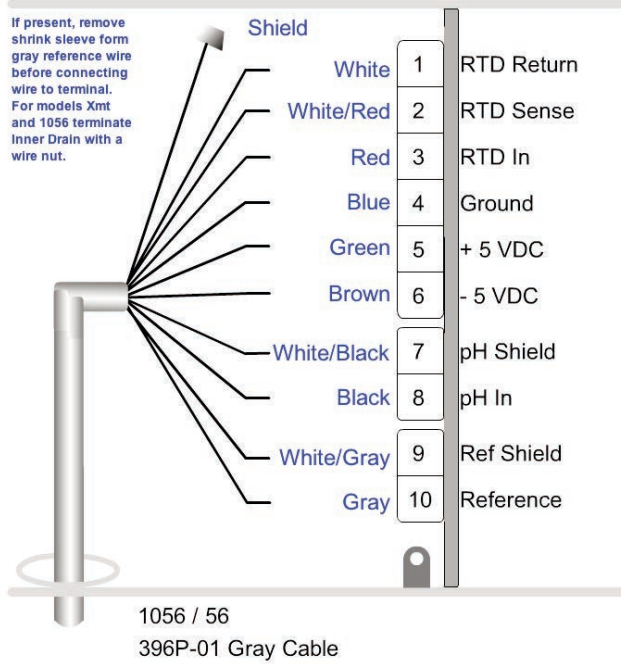

Figure 3-14. Wiring for 396P-01 (Blue Cable) and 1056/56

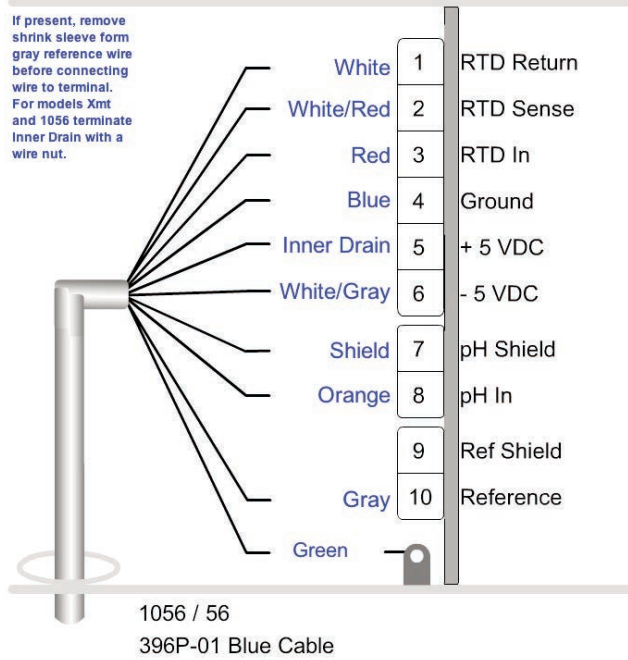

Figure 3-15. Wiring for 396P-02 (Gray Cable) and 1056/56

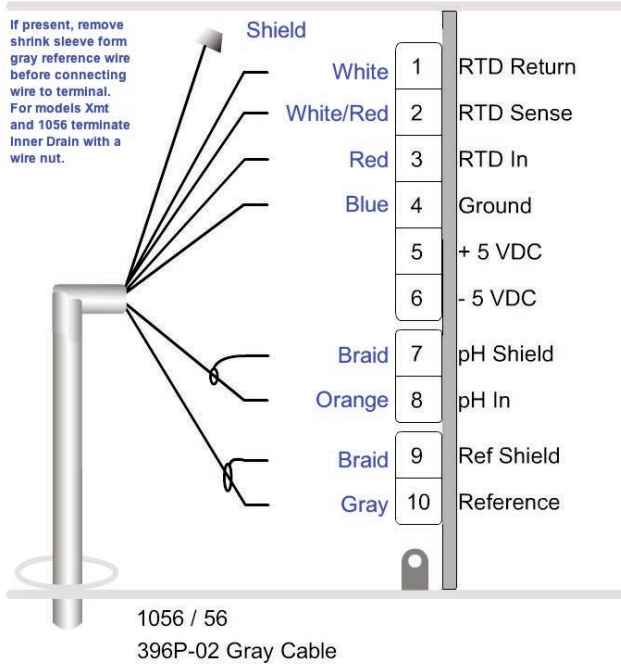

Figure 3-16. Wiring for 396P-02 (Blue Cable) and 1056/56

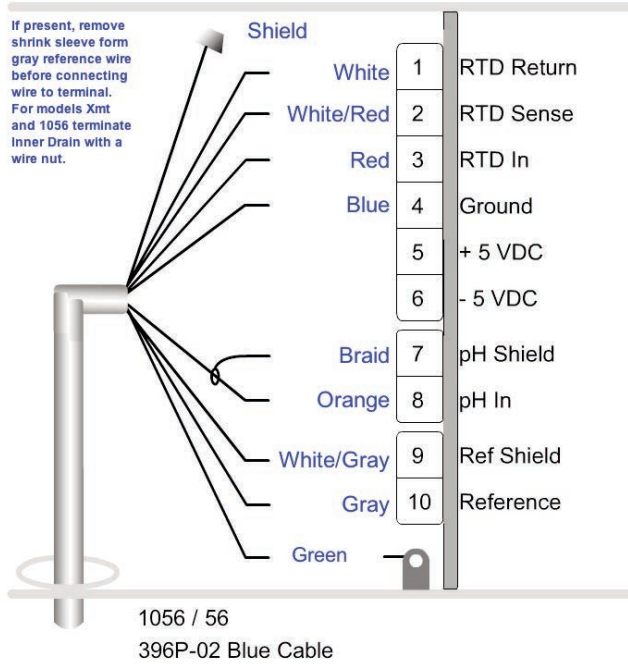

Figure 3-17. Wiring for 396PVP (Gray Cable) and 1056/56

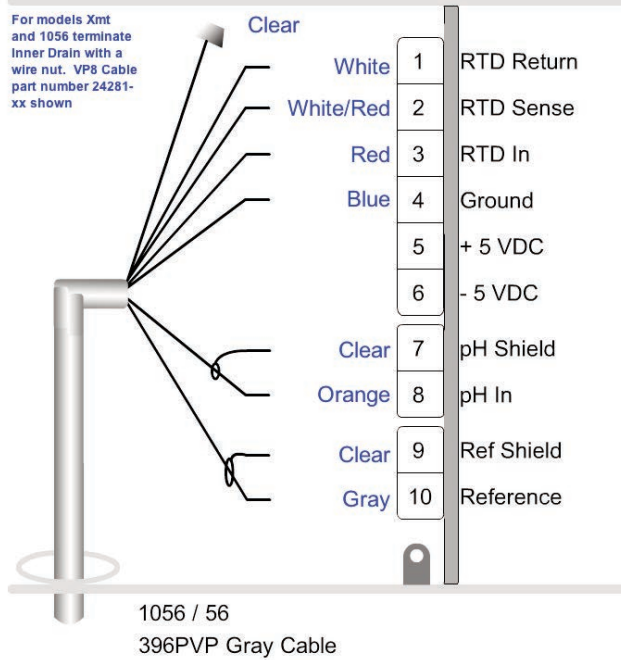

Figure 3-18. Wiring for 396P-01 (Blue Cable) and 1056/56

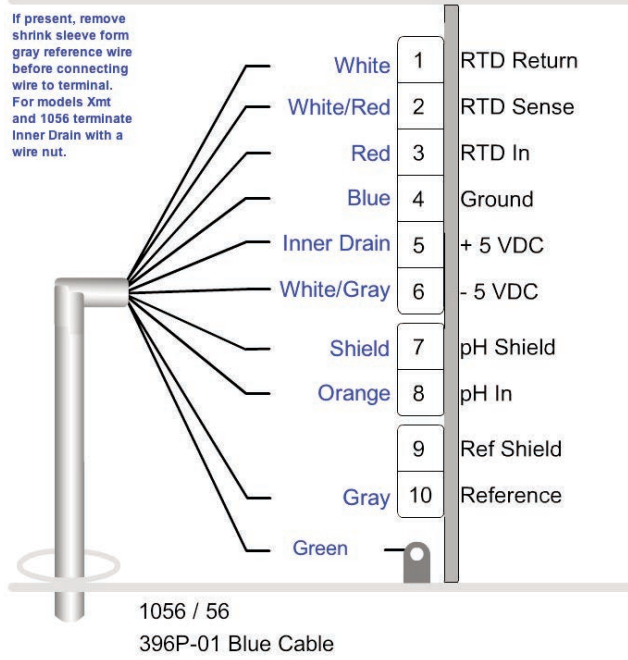

Figure 3-19. Wiring for 396VP-70 (Blue Cable) and 1056/1057/56

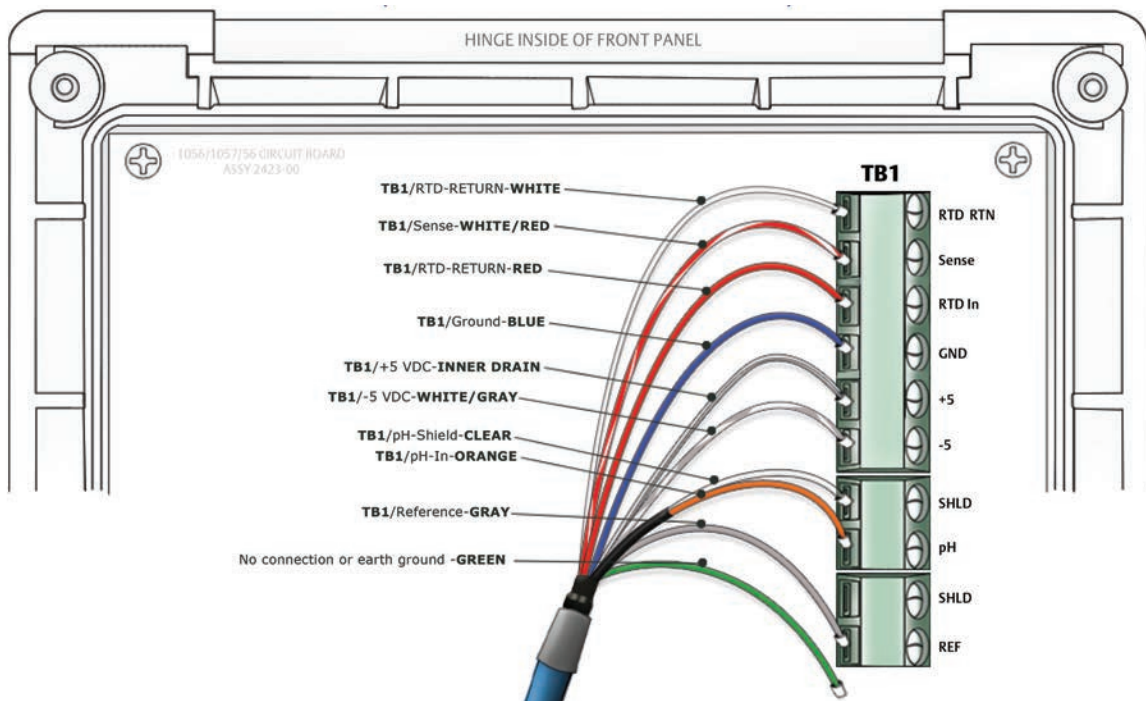

Figure 3-20. Wiring for 396P-01 (Gray Cable) and 1057

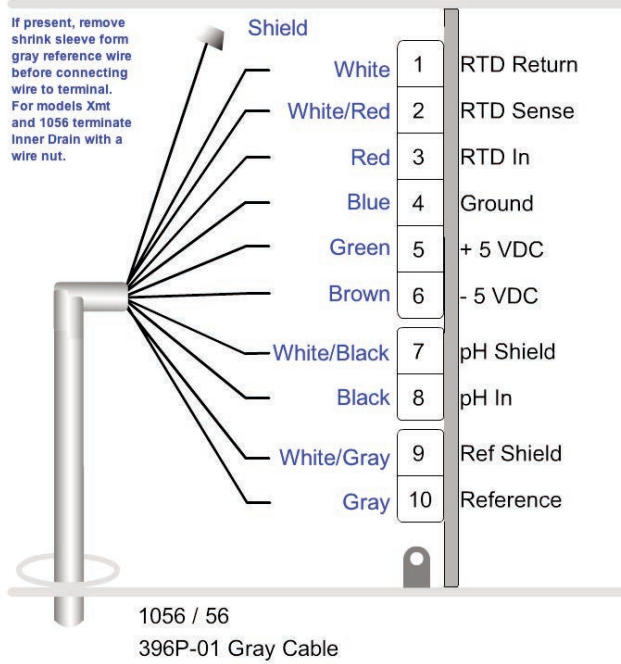

Figure 3-21. Wiring for 396P-01 (Blue Cable) and 1057

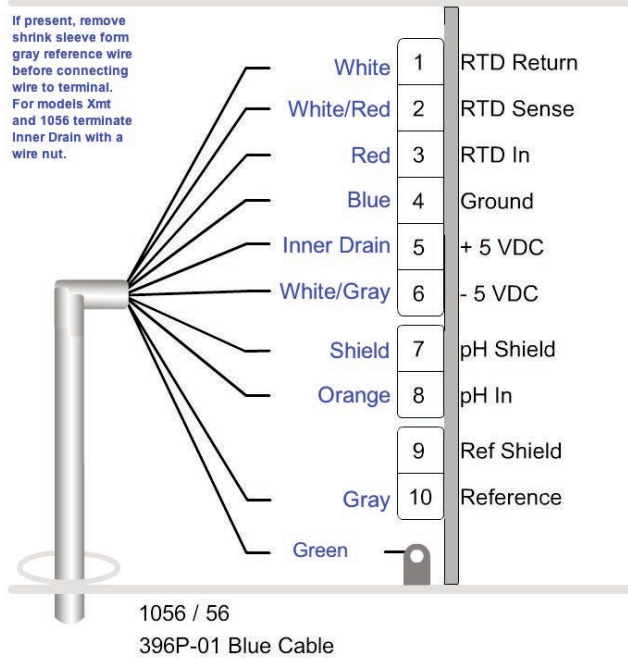

Figure 3-22. Wiring for 396P-02 (Gray Cable) and 1057

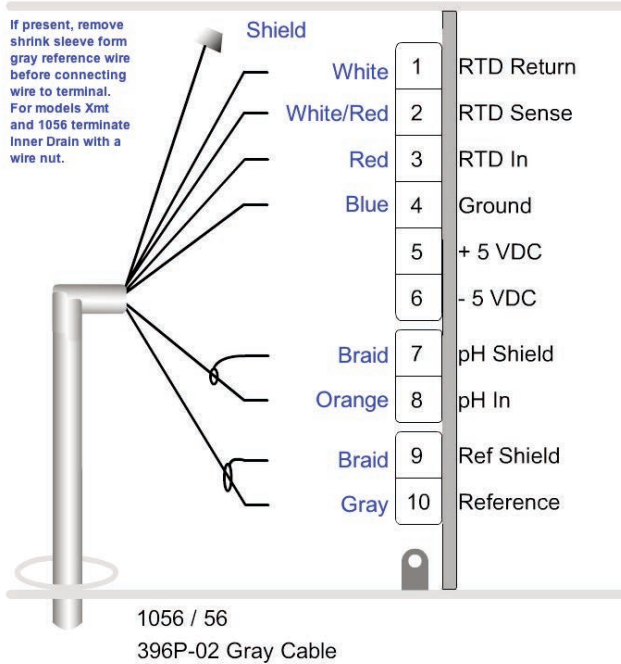

Figure 3-23. Wiring for 396P-02 (Blue Cable) and 1057

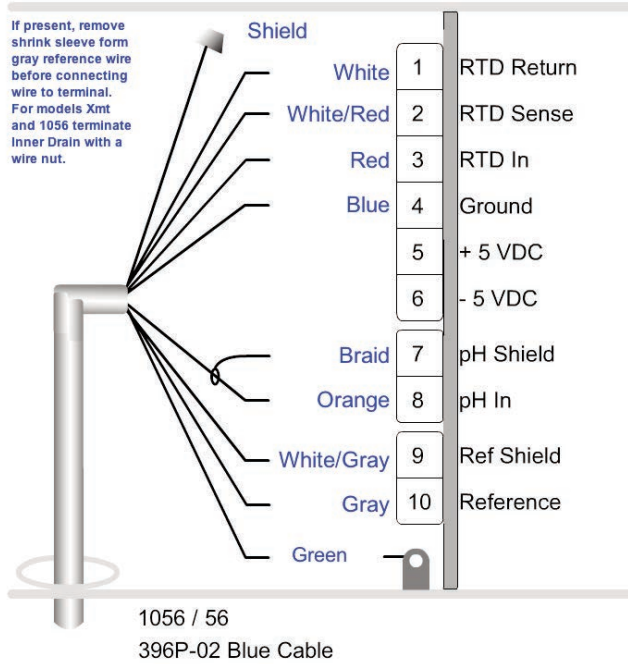

Figure 3-24. Wiring for 396PVP (Gray Cable) and 1057

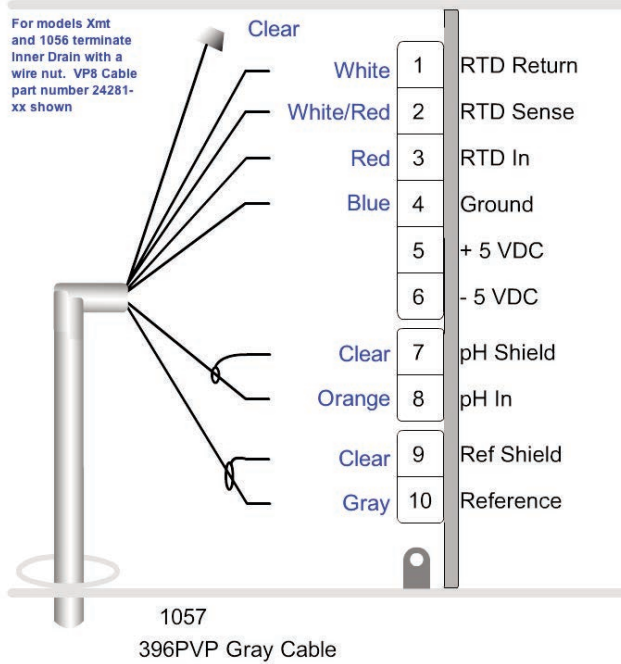

Figure 3-25. Wiring for 396PVP (Blue Cable) and 1057

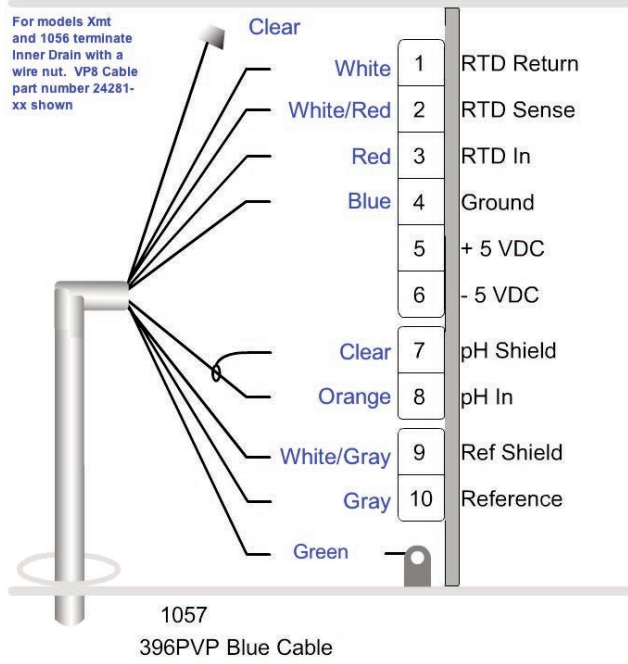

Figure 3-26. Wiring for 396P-01 and 1066

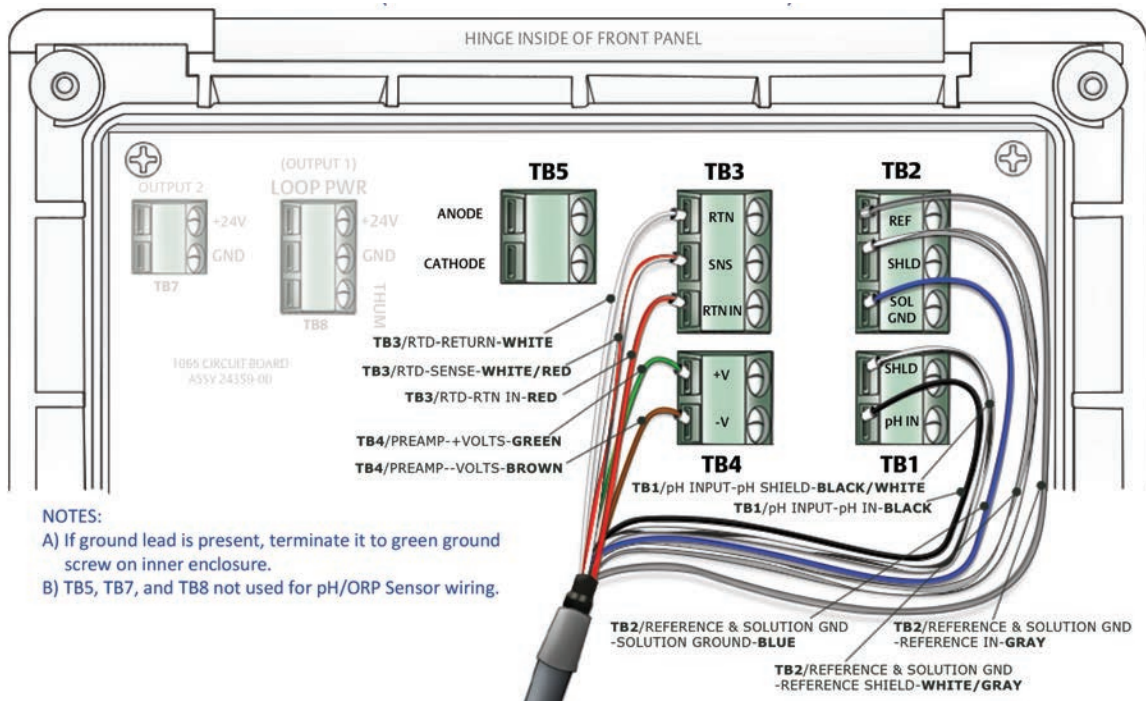

Figure 3-27. Wiring for 396P-01 (Blue Cable) and 1066

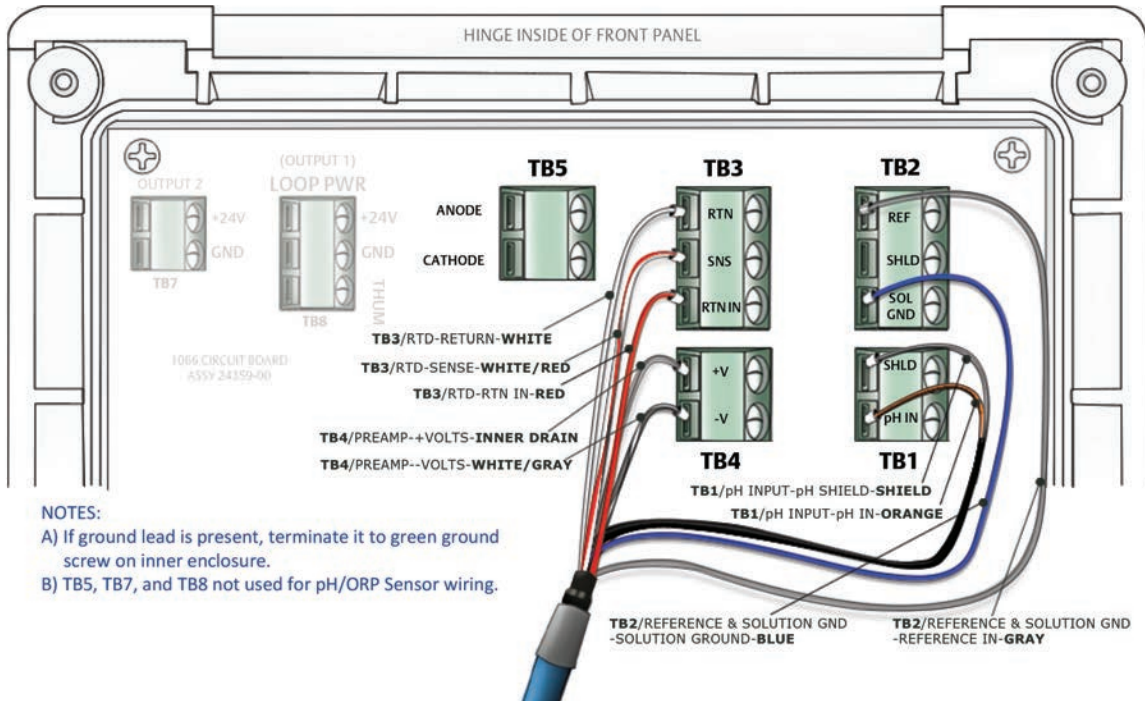

Figure 3-28. Wiring for 396P-02 and 1066

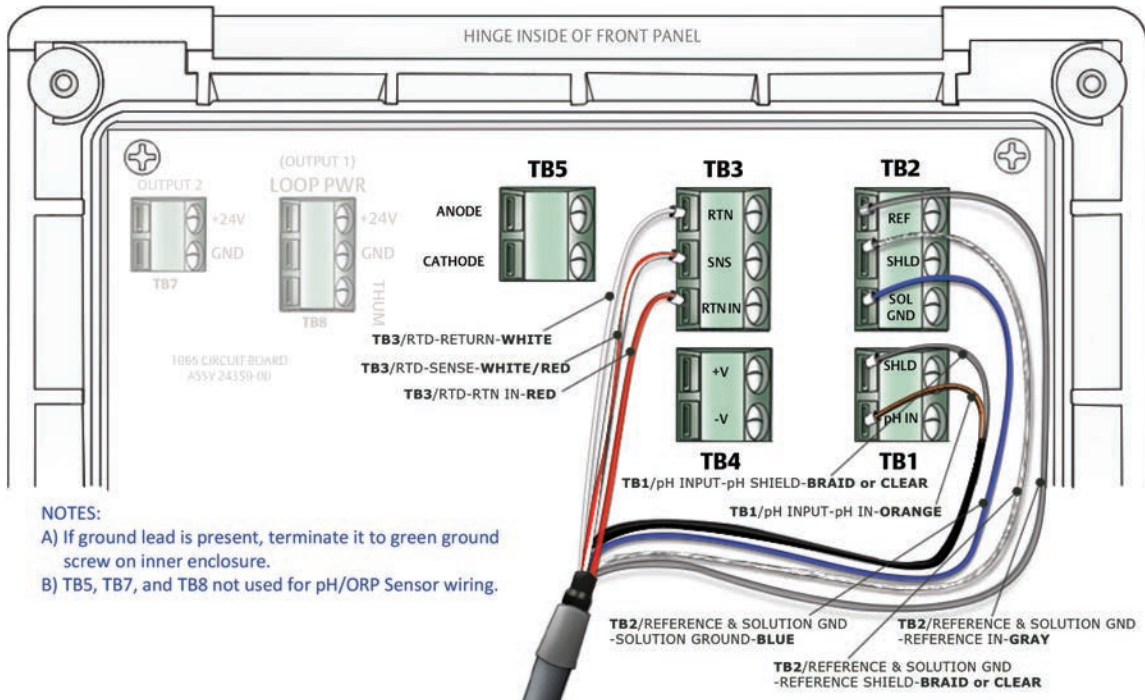

Figure 3-29. Wiring for 396P-02 (Blue Cable) and 1066

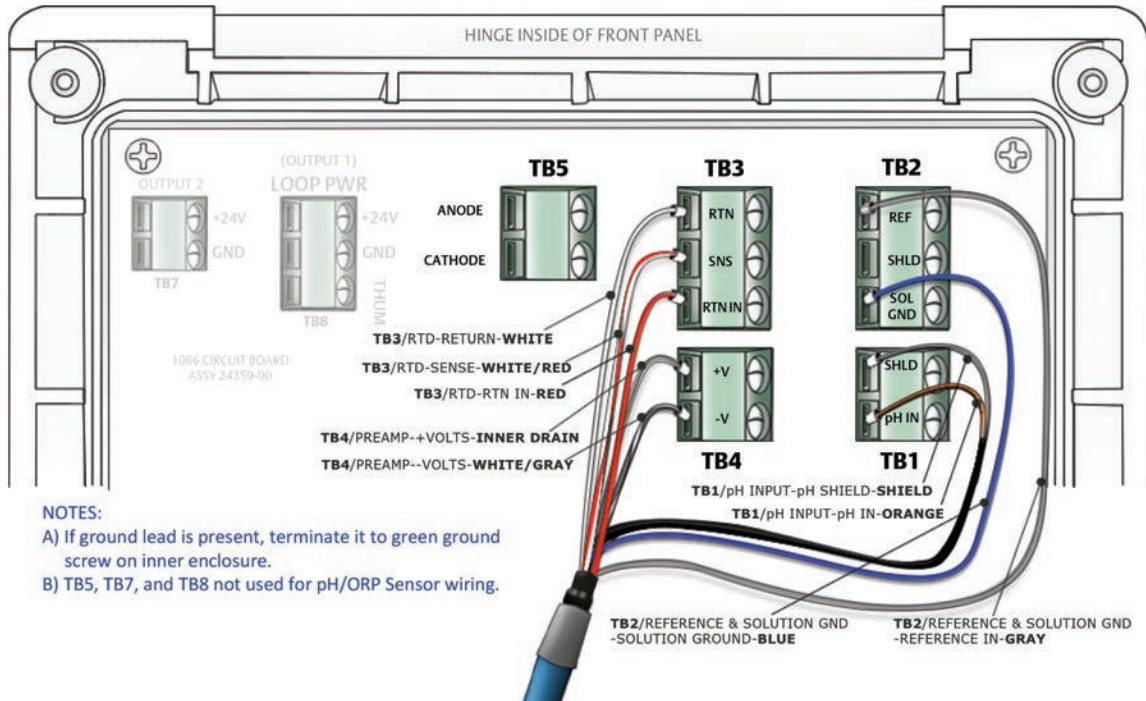

Figure 3-30. Wiring for 396PVP and 1066

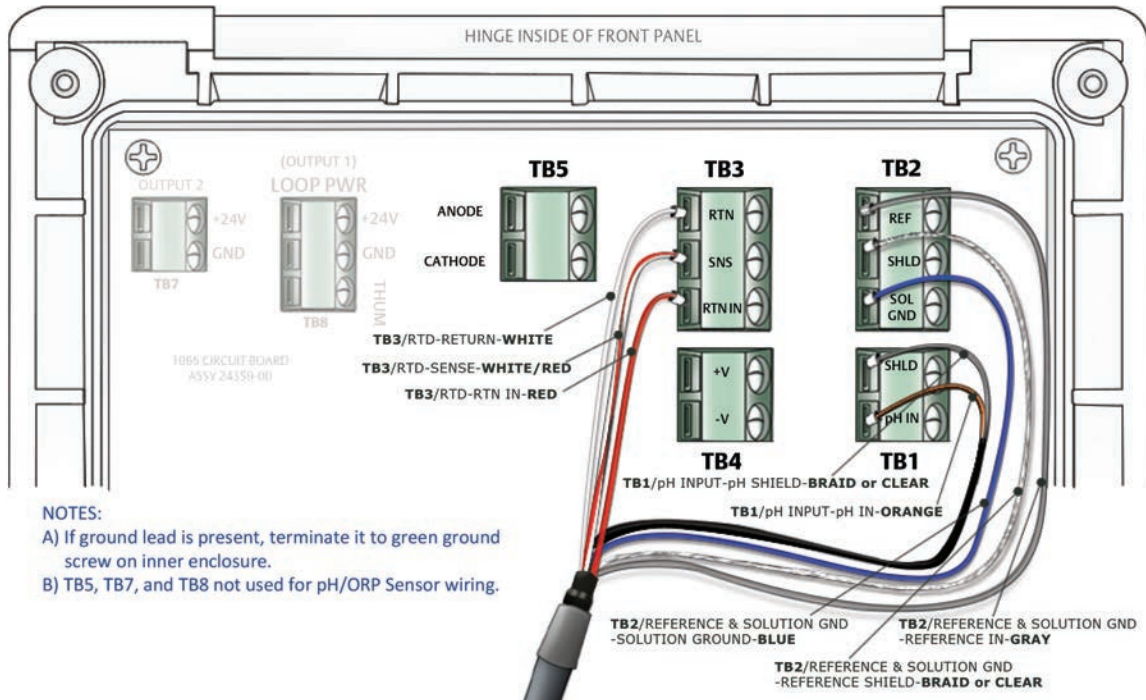

Figure 3-31. Wiring for 396PVP (Blue Cable) and 1066

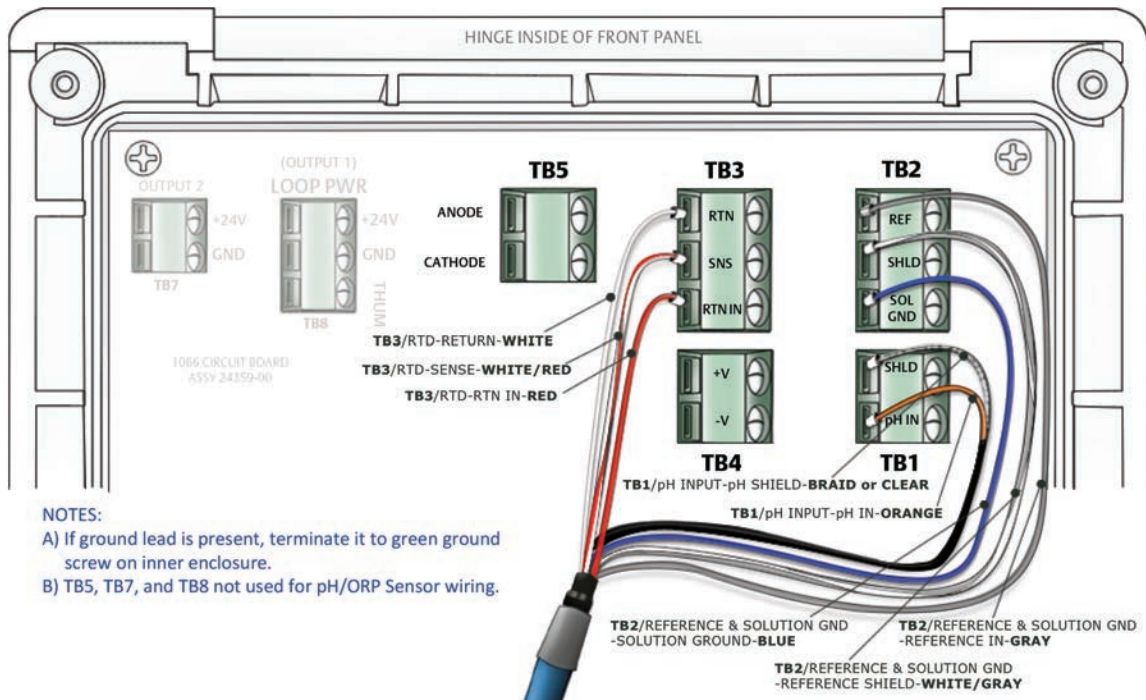

Figure 3-32. Wiring for 396PVP-70 (Blue Cable) and 1066

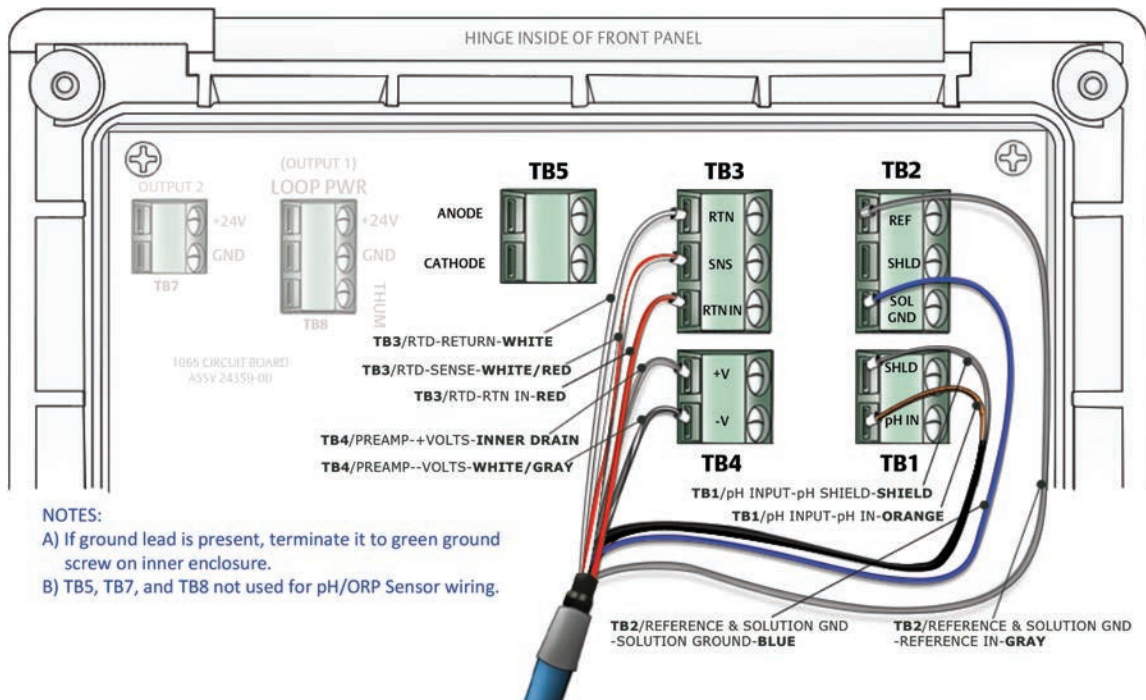

Figure 3-33. Wiring for 396P-01 (Gray Cable) and 5081-P-HT

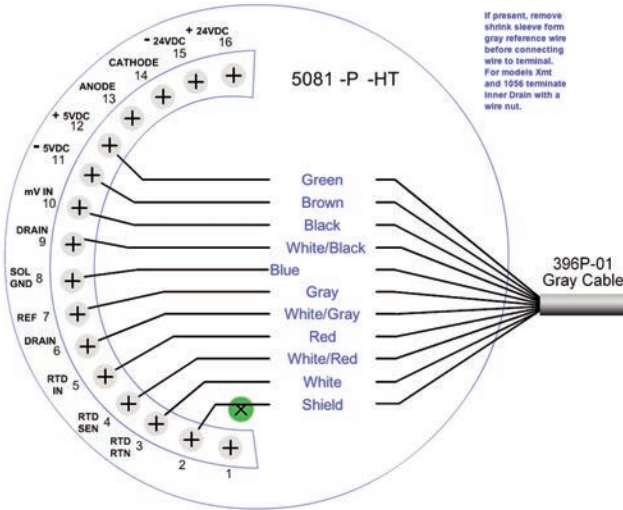

Figure 3-34. Wiring for 396P-01 (Blue Cable) and 5081-P-HT

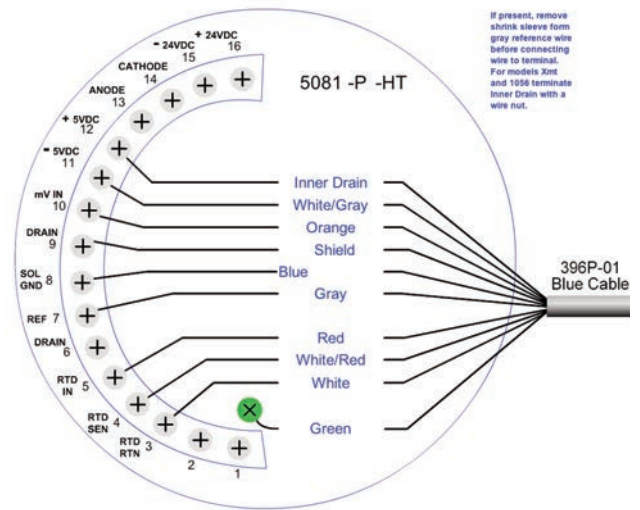

Figure 3-35. Wiring for 396P-02 (Gray Cable) and 5081-P-HT

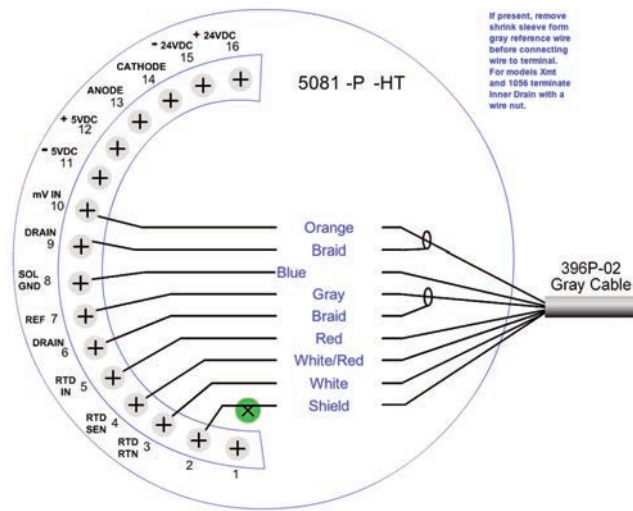

Figure 3-36. Wiring for 396P-02 (Blue Cable) and 5081-P-HT

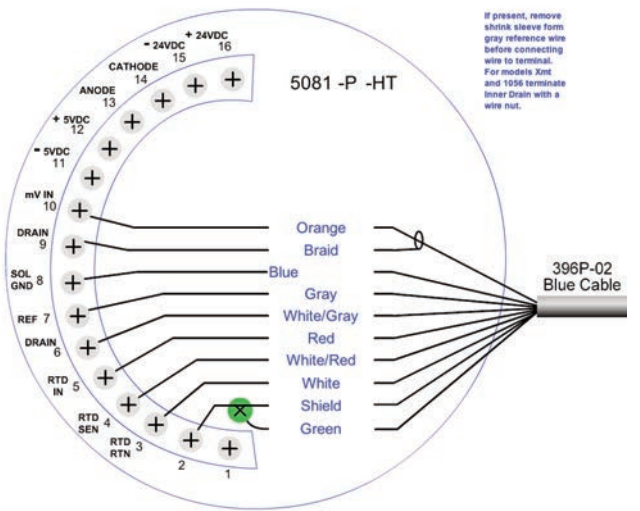

Figure 3-37. Wiring for 396PVP (Gray Cable) and 5081-P-HT

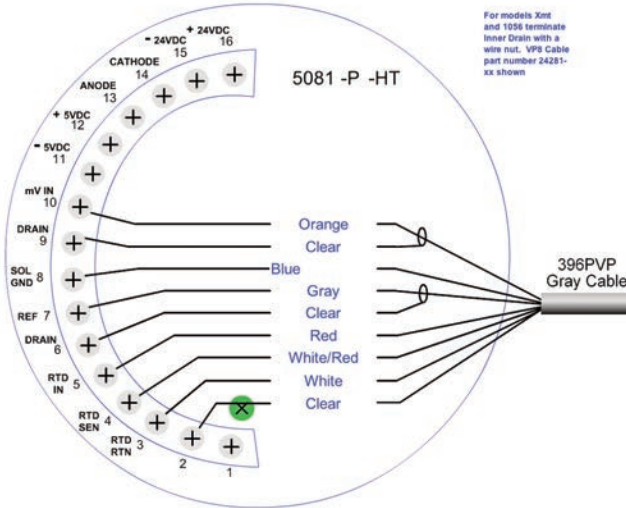

Figure 3-38. Wiring for 396PVP (Blue Cable) and 5081-P-HT

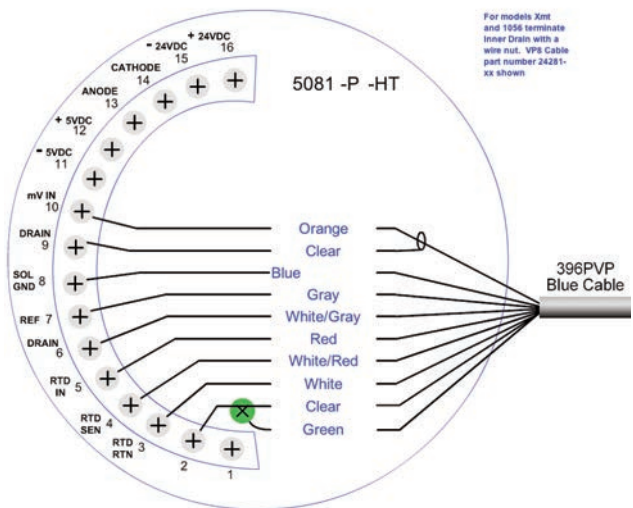

Figure 3-39. Wiring for 396PVP-70 (Gray Cable) and 5081

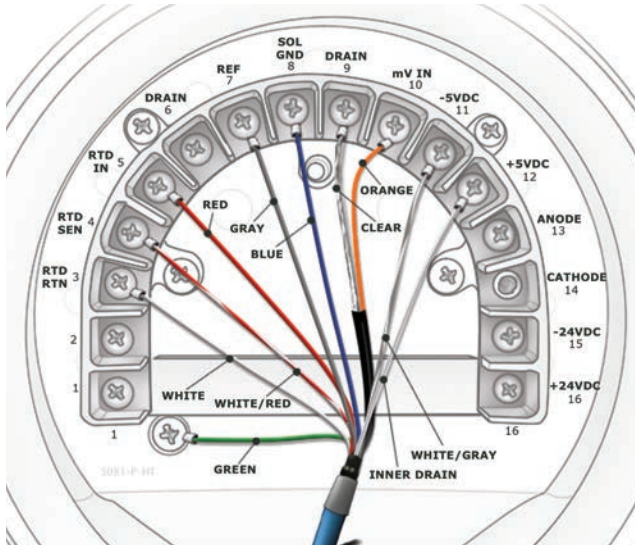

Figure 3-40. Wiring for 396PVP-70 (Gray Cable) and 6081

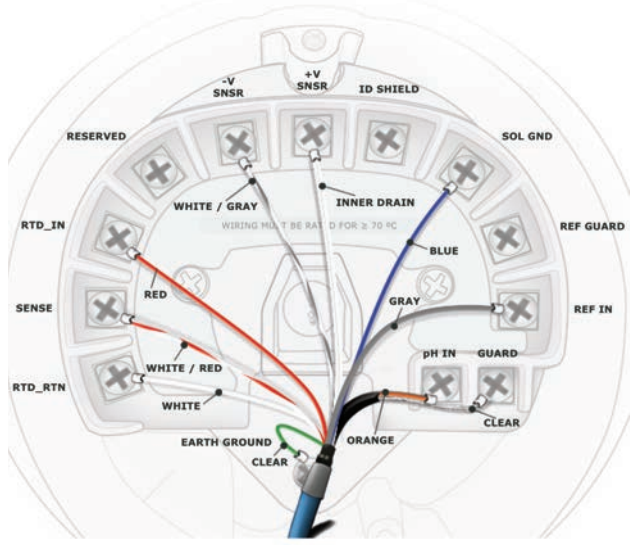

Figure 3-41. Wiring for 396P-01 (Gray Cable) and 6081

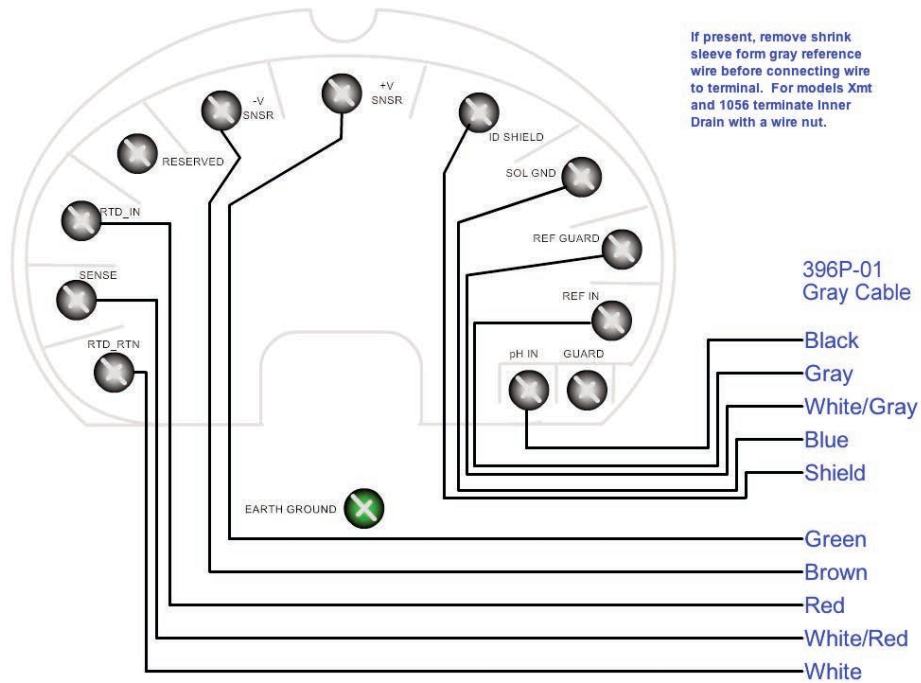

Figure 3-42. Wiring for 396P-01 (Blue Cable) and 6081

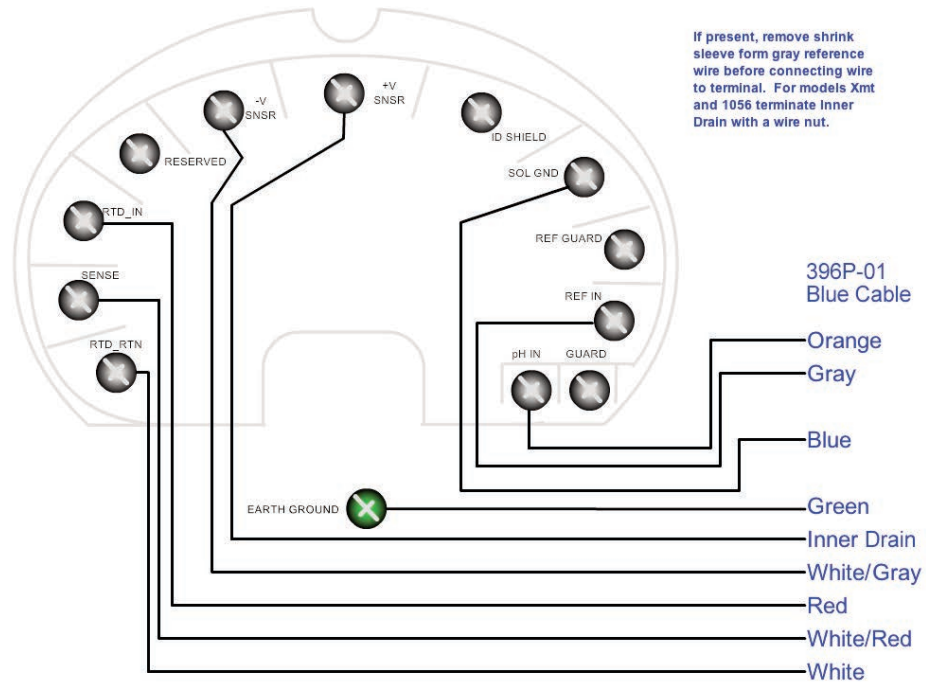

Figure 3-43. Wiring for 396P-02 (Gray Cable) and 6081

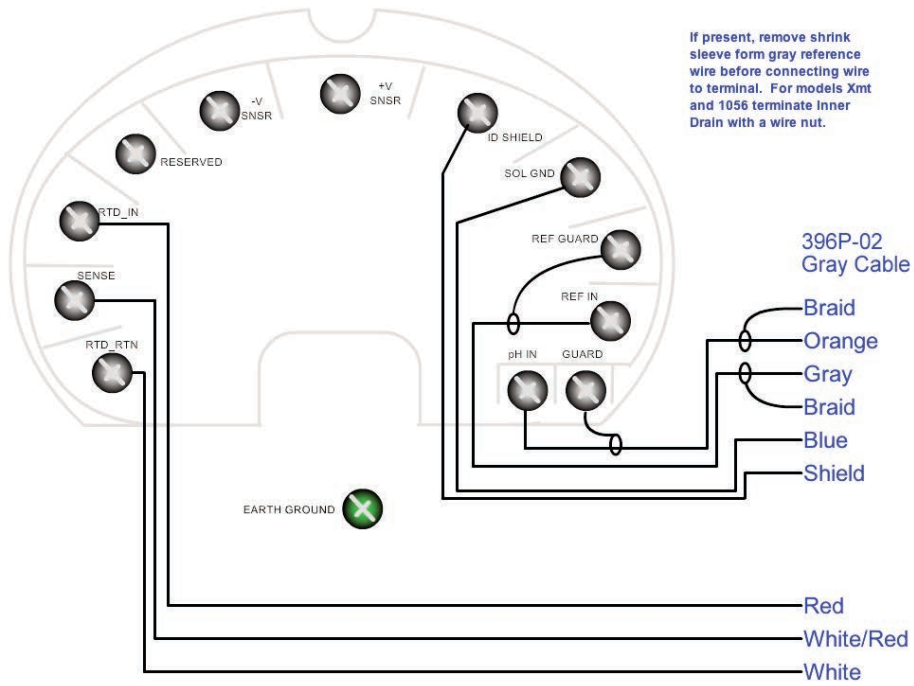

Figure 3-44. Wiring for 396P-02 (Blue Cable) and 6081

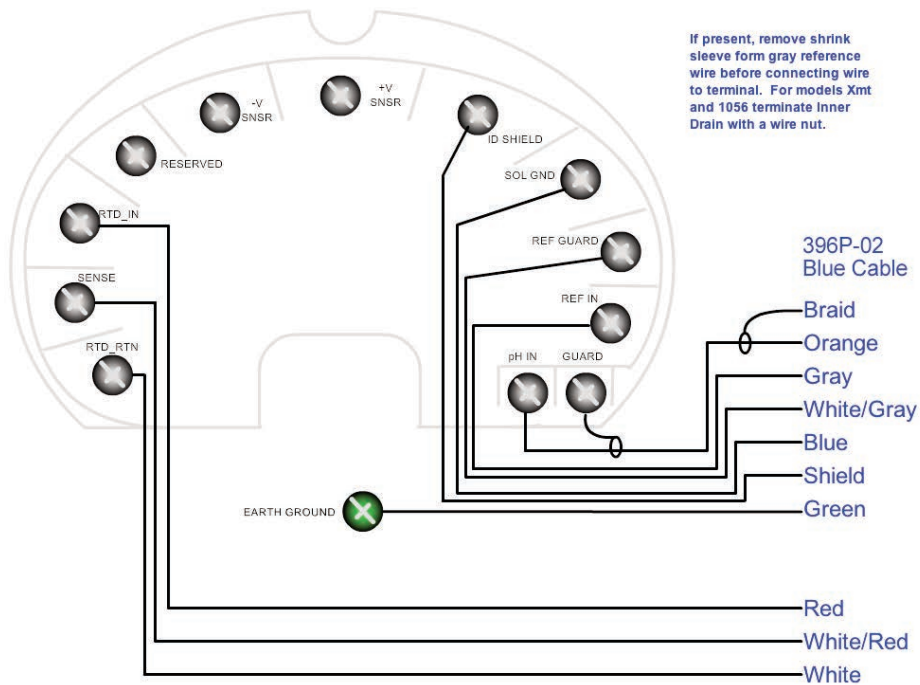

Figure 3-45. Wiring for 396PVP (Gray Cable) and 6081

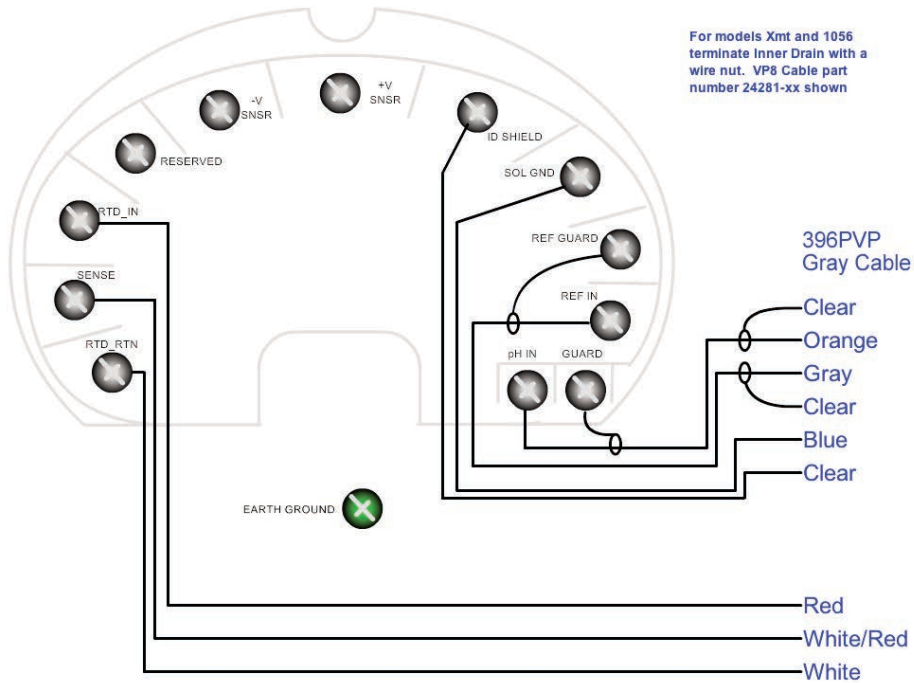

Figure 3-46. Wiring for 396PVP (Blue Cable) and 6081

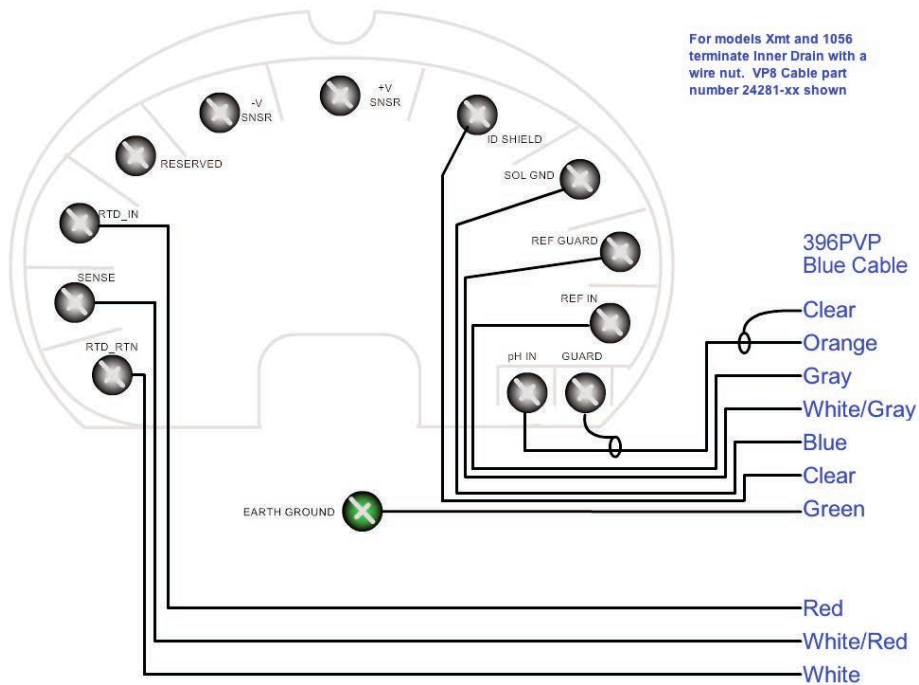

Figure 3-47. Wiring for 396P-01 (Gray Cable) and Xmt

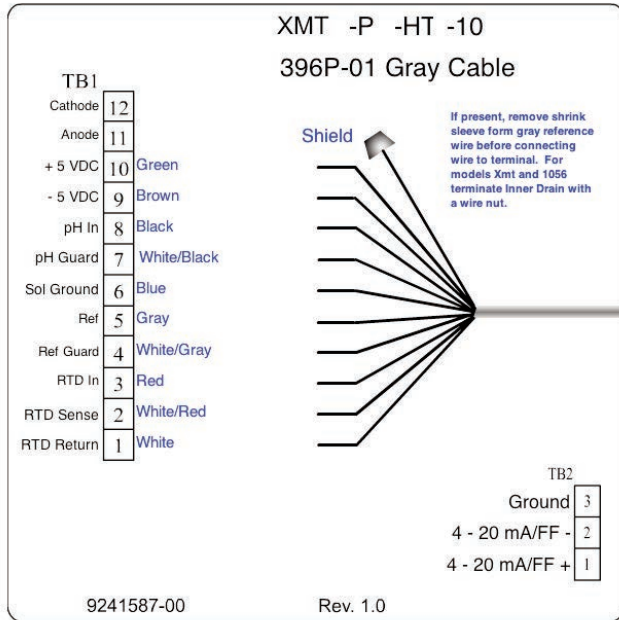

Figure 3-48. Wiring for 396P-01 (Blue Cable) and Xmt

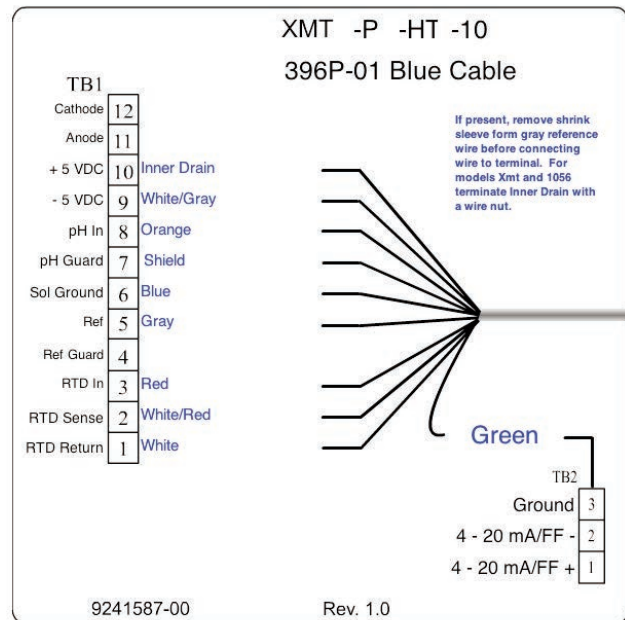

Figure 3-49. Wiring for 396P-02 (Gray Cable) and Xmt

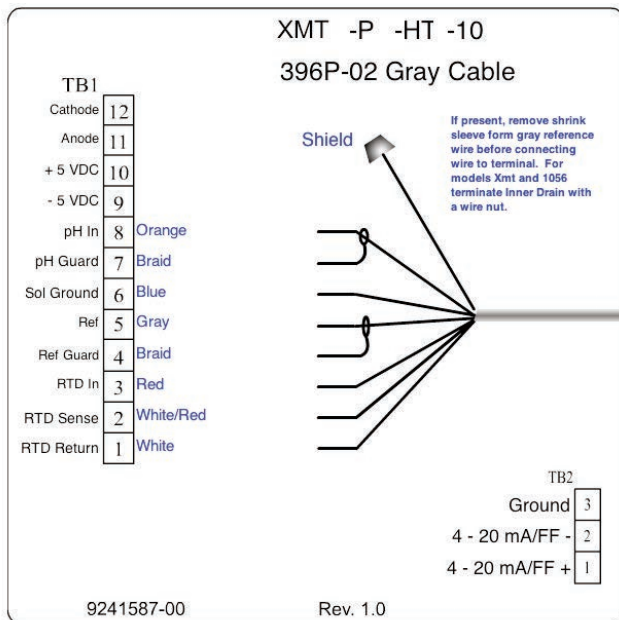

Figure 3-50. Wiring for 396P-02 (Blue Cable) and Xmt

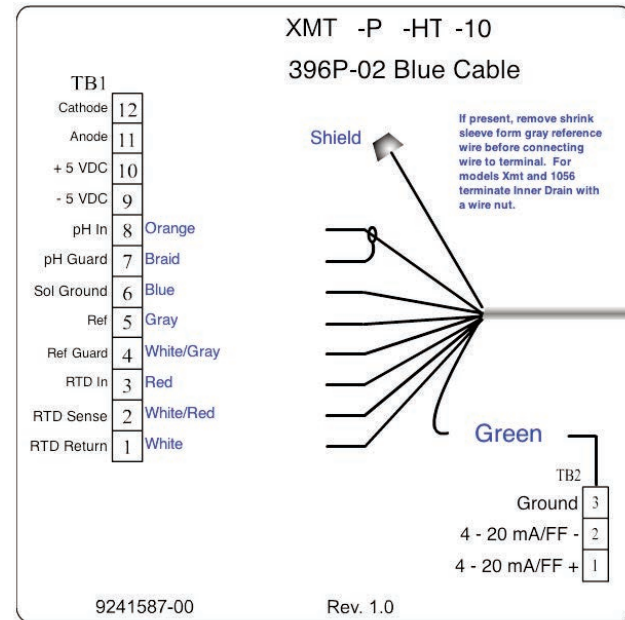

Figure 3-51. Wiring for 396PVP (Gray Cable) and Xmt

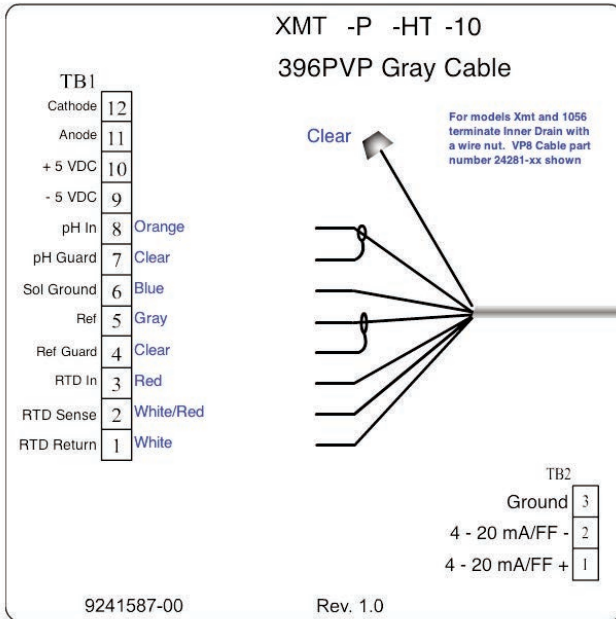

Figure 3-52. Wiring for 396PVP (Blue Cable) and Xmt

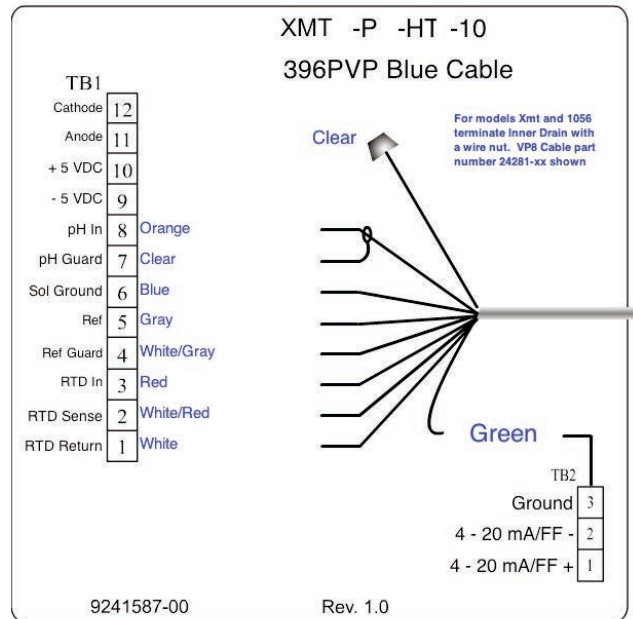

Figure 3-53. Wiring Details for 396PVP or 396P-02-55 with Mating Variopole Cable for use with 81

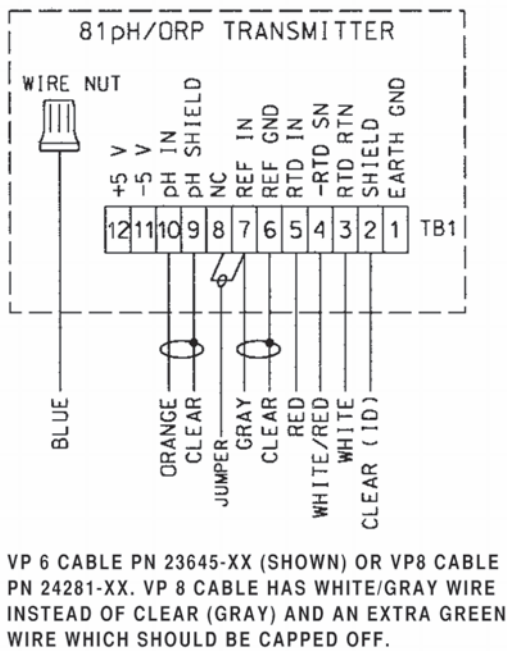

Figure 3-54. Wiring Details for 396PVP or 396P-02-50 with Mating Variopole Cable for use with 1181

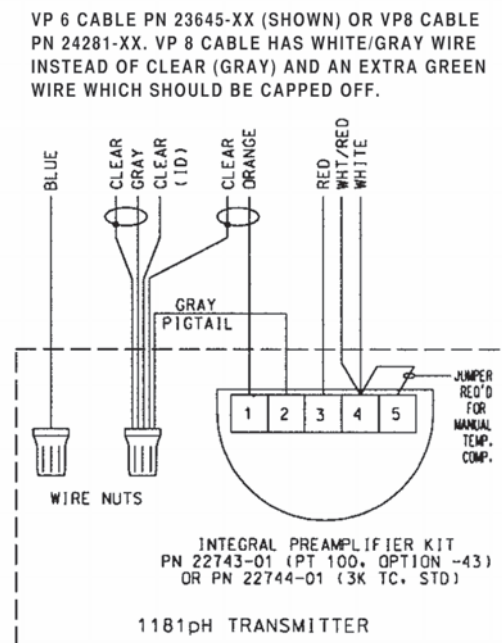
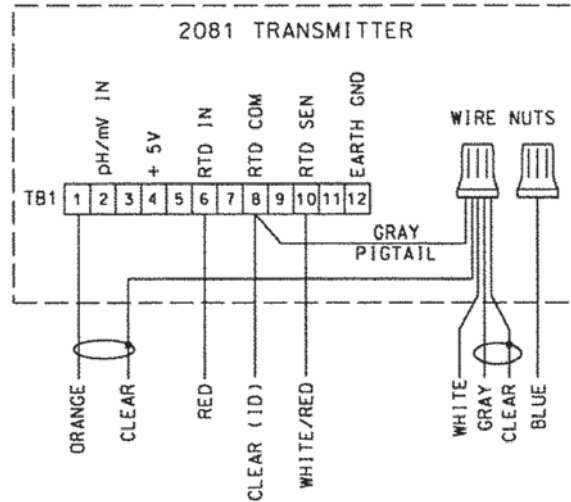
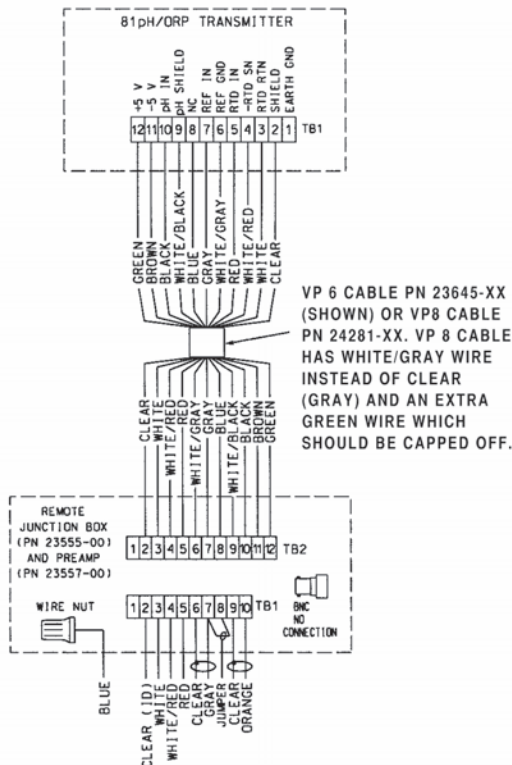

Figure 3-55. Wiring Details for 396PVP or 396P-02-54 with Mating Variopool Cable for use with 2081



VP 6 CABLE PN 23645-XX (SHOWN) OR VP 8 CABLE PN 24281-XX. VP 8 CABLE HAS WHITE/GRAY WIRE INSTEAD OF CLEAR (GRAY) AND AN EXTRA GREEN WIRE WHICH SHOULD BE CAPPED OFF.

Figure 3-56. Wiring Details for 396PVP or 396P-02-55 with Mating Variopool Cable for use with Remote Junction Box (PN 23555-00) to 81



VP 6 CABLE PN 23645-XX (SHOWN) OR VP 8 CABLE PN 24281-XX. VP 8 CABLE HAS WHITE/GRAY WIRE INSTEAD OF CLEAR (GRAY) AND AN EXTRA GREEN WIRE WHICH SHOULD BE CAPPED OFF.

Figure 3-57. Wiring Details for 396PVP or 396P-02-50 with Mating Variopool Cable for use with Remote Junction Box (PN 23309-03) to 1181

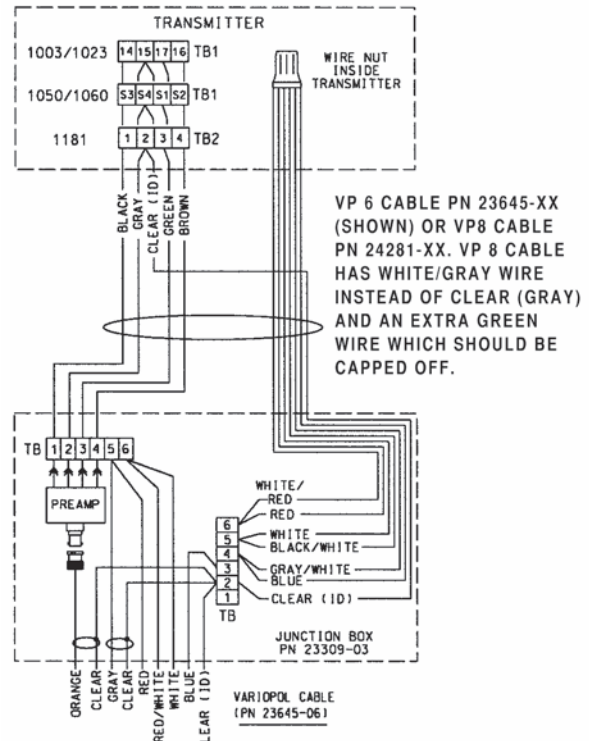

VP 6 CABLE PN 23645-XX (SHOWN) OR VP 8 CABLE PN 24281-XX. VP 8 CABLE HAS WHITE/GRAY WIRE INSTEAD OF CLEAR (GRAY) AND AN EXTRA GREEN WIRE WHICH SHOULD BE CAPPED OFF.

Figure 3-58. Wiring Details for 396PVP or 396P-02-54 with Mating Variopol Cable for use with 1054A/B & 2054

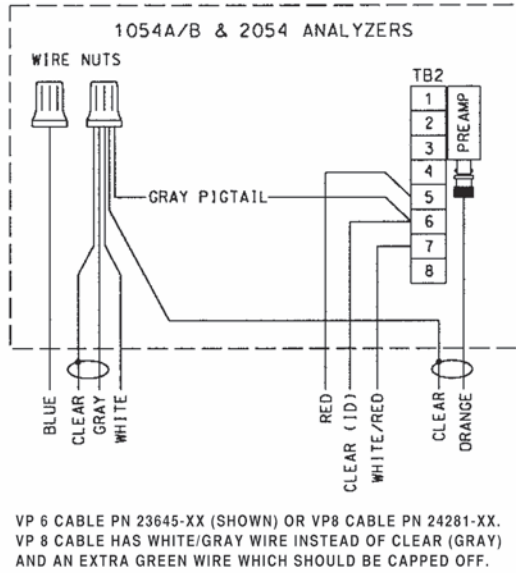
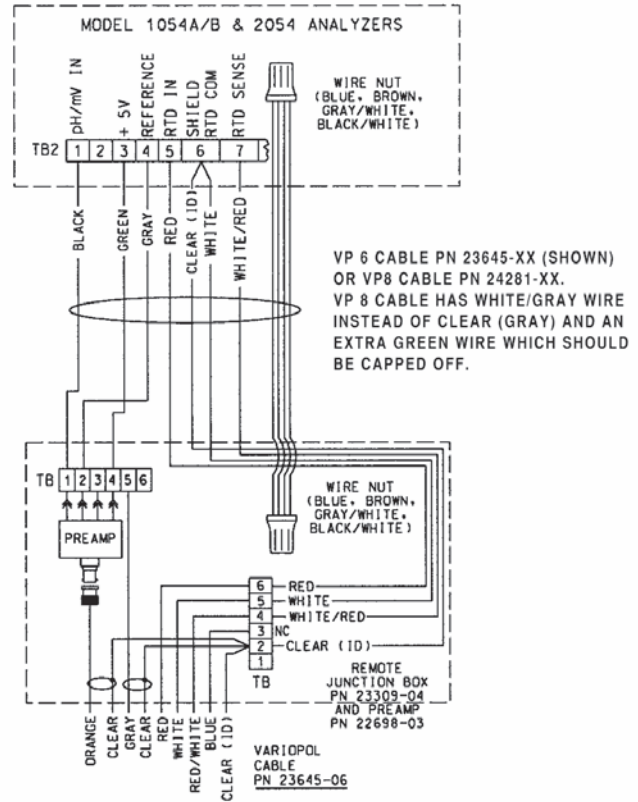

Figure 3-59. Wiring Details for 396PVP or 396P-02-54 with Mating Variopol Cable for use with 1054



Section 4: Start-Up and Calibration

4.1 Rosemount 396P and 396PVP pH Sensors

4.1.1 Sensor preparation

Shake down the sensor to remove any air bubbles that may be present at the tip of the pH glass bulb. In most cases, the pH sensor can simply be installed as shipped and readings with an accuracy of ± 0.6 pH may be obtained. To obtain greater accuracy or to verify proper operation, the sensor must be calibrated as a loop with its compatible analyzer or transmitter.

4.1.2 pH Calibration

After a temporary connection is established between the sensor and the instrument, a buffer calibration may be performed. Consult appropriate pH/ORP analyzer or transmitter Reference Manual for specific calibration and standardization procedures, or see below for recommended two-point buffer calibration procedure.

Recommended two-point buffer calibration procedure:

Select two stable buffer solutions, preferably pH 4.0 and 7.0 (pH buffers other than pH 4.0 and pH 7.0 can be used as long as the pH values are at least two pH units apart).

NOTE: A pH 7.0 buffer solution reads a mV value of approximately zero, and pH buffers read approximately 59.1 mV for each pH unit above or below pH 7.0. Check the pH buffer manufacturer specifications for millivolt values at various temperatures since it may affect the actual value of the buffer solution mV/pH value.

1. Immerse sensor in the first buffer solution. Allow sensor to adjust to the buffer temperature (to avoid errors due to temperature differences between the buffer solution and sensor temperature) and wait for reading to stabilize. Value of buffer can now be acknowledged by analyzer/transmitter.
2. Once the first buffer has been acknowledged by the analyzer/transmitter, rinse the buffer solution off of the sensor with distilled or deionized water.
3. Repeat steps 1 and 2 using the second buffer solution.
4. Once the analyzer/transmitter has acknowledged both buffer solutions, a sensor slope (mV/pH) is established (the slope value can be found within the analyzer/ transmitter).
5. The slope value should read about 59.1 mV/pH for a new sensor and will decrease over time to approximately 47-49 mV/pH. Once the slope reads below the 47-49 mV/pH range, a new sensor should be installed to maintain accurate readings.

Recommended pH Sensor Standardization:

For maximum accuracy, the sensor can be standardized online or with a process grab sample after a buffer calibration has been performed and the sensor has been conditioned to the process. Standardization accounts for the sensor junction potential and other interferences. Standardization will not change the sensor's slope but will simply adjust the analyzer's reading to match that of the known process pH.

1. While obtaining a process solution sample (it is recommended that the sample is taken close to the sensor), record the pH value that is shown on the analyzer/transmitter display.

2. Measure and record the pH of the process solution sample with another temperature compensated, calibrated pH instrument. For best results, standardization should be performed at the process temperature.
3. Adjust the analyzer/transmitter value to the standardized value.

4.2 Rosemount 396P and 396PVP ORP Sensors

4.2.1 Sensor preparation

Most industrial applications have a number of ORP reactions occurring in sequence or simultaneously. There can be several components that are oxidized or reduced by the reagents that are used. Theoretically, the ORP potential is absolute because it is the result of the oxidation-reduction equilibrium. However, the actual measured potential is dependent on many factors, including the condition of the surface of the ORP platinum electrode. Therefore, the sensor should be allowed 1-2 hours to become “conditioned” to the stream when first set-up or after being cleaned.

4.2.2 ORP Calibration

1. Make a temporary electrical connection between the sensor and the instrument.
2. Obtain an ORP standard solution, or a standard solution can also be made quite simply by adding a few crystals of quinhydrone to either pH 4 or pH 7 buffer. Quinhydrone is only slightly soluble therefore a few crystals will be required. (Refer to Section 4.3. for an alternate ORP standard solution).
3. Immerse the sensor in the standard solution. Allow 1-2 minutes for the ORP sensor to stabilize.
4. Adjust the standardize control of the instrument to the solution value shown in Table 5-1 (below) or on the label of the standard solution. The resulting potentials, measured with a clean platinum electrode and saturated KCl/AgCl reference electrode, should be within ± 20 millivolts of the value. Solution temperature must be noted to ensure accurate interpretation of results. The ORP value of saturated quinhydrone solution is not stable over long periods of time. Therefore, these standards should be made up fresh each time they are used.
5. Remove the sensor from the buffer, rinse and install in the process.

TABLE 4-1. ORP of Saturated Quinhydrone Solution (In Millivolts)

	pH 4 Solution			pH 7 Solution		
Temp °C	20	25	30	20	25	30
Millivolt Potential	268	264	260	94	87	80

Section 5: Maintenance

5.1 General Information

The Rosemount 396P and 396PVP Sensors require minimum maintenance. The sensor should be kept clean and free of debris and sediment at all times. The frequency of cleaning by wiping or brushing with a soft cloth or brush is determined by the nature of the solution being measured. The sensor should be removed from the process periodically and checked in buffer solutions.



BEFORE REMOVING THE SENSOR, be absolutely certain that the process pressure is reduced to 0 psig and the process temperature is lowered to a safe level!

If the sensor will not calibrate, refer to your analyzer/ transmitter Reference Manual for proper test procedures. If it is determined that the sensor has failed, it

5.2 Automatic Temperature Compensator

The temperature compensator element is temperature sensitive and can be checked with an ohmmeter. Resistance increases with temperature.

The 3K element will read 3000 ohms $\pm 1\%$ at 25°C (77°F) and a Pt100 will read 110 ohms. Resistance varies with temperature for a 3K and Pt100 element and can be determined according to Table 6-2 or the following formula:

$$R_T = R_0 [1 + R_1 (T - 20)]$$

Where R_T = Resistance

T = Temperature in °C

Refer to Table 6-1 for R_0 and R_1 values

5.3 Rosemount 396P and 396PVP pH Sensors

5.3.1 Electrode Cleaning

If the electrode is coated or dirty, clean as follows:

1. Remove the sensor from process.
2. Wipe the glass bulb with a soft, clean, lint free cloth or tissue. If this does not remove the dirt or coating, go to Step 3. (Detergents clean oil and grease; acids remove scale.)
3. Wash the glass bulb in a mild detergent solution and rinse it in clean water. If this does not clean the glass bulb, go to Step 4.



The solution used during the following check is an acid and should be handled with care. Follow the directions of the acid manufacturer. Wear the proper protective equipment. Do not let the solution come in contact with skin or clothing. If contact with skin is made, immediately rinse with clean water.

4. Wash the glass bulb in a dilute 5% hydrochloric acid solution and rinse with clean water. Soaking the sensor overnight in the acid solution can improve cleaning action.

NOTE: Erroneous pH results may result immediately after acid soak, due to reference junction potential build-up. Replace the sensor if cleaning does not restore sensor operation.

TABLE 5-1. Ro and R1 Values for Temperature Compensation Elements

Temperature Compensation Element	R ₀	R ₁
3K	2934	.0045
Pt100	107.7	.00385

TABLE 5-2. Temperature vs Resistance of Auto T.C. Elements

Temperature °C	Resistance (Ohms) ±1%	
	3K	Pt100
0	2670	100.0
10	2802	103.8
20	2934	107.7
25	3000	109.6
30	3066	111.5
40	3198	115.4
50	3330	119.2
60	3462	123.1
70	3594	126.9
80	3726	130.8
90	3858	134.6
100	3990	138.5

5.4 Rosemount 396P and 396PVP ORP

5.4.1 Platinum Electrode Check

The platinum electrode may be checked as follows: There are two types of standard solutions which may be used to check the ORP electrode/transmitter system.

Type 1: One type of commonly used ORP standard solution is the saturated quinhydrone solution. Refer to Section 5.2.

 CAUTION

The solution used during the following check is an acid and should be handled with care. Follow the directions of the acid manufacturer. Wear the proper protective equipment. If contact with skin or clothing is made, immediately rinse with plenty of clean water.

Type 2: A second ORP standard solution is the Ferric-Ferrous Ammonium Sulfate Solution (PN R508-16OZ), and it can be ordered as a spare part; otherwise, it can be prepared from the following recipe: Dissolve 39.2 grams of reagent grade ferrous ammonium sulfate, $\text{Fe}(\text{NH}_4)_2(\text{SO}_4)_2 \cdot 6\text{H}_2\text{O}$ and 48.2 grams of reagent grade ferric ammonium sulfate, $\text{FeNH}_4(\text{SO}_4)_2 \cdot 12\text{H}_2\text{O}$, in approximately 700 milliliters of water (distilled water is preferred, but tap water is acceptable). Slowly and carefully add 56.2 milliliters of concentrated sulfuric acid. Add sufficient water to bring the total solution volume up to 1000 ml. This standard ORP solution, although not as simple to prepare as the quinhydrone recipe, is much more stable, and will maintain its millivolt value for approximately one year when stored in glass containers. This solution (ferric/ferrous ammonium sulfate) will produce a nominal ORP of 476 +20 mV at 25°C when used with a saturated KCl/AgCl reference electrode and platinum measuring electrode. Some

tolerance in mV values is to be expected due to the rather large liquid reference junction potentials which can arise when measuring this strongly acidic and concentrated solution. However, if the measuring electrodes are kept clean and in good operating condition, consistently repeatable calibrations can be carried out using this standard solution.

5.4.2 Cleaning Platinum Electrode

The electrode can be restored to normal operation by simply cleaning the platinum electrode with baking soda. Polish it by rubbing it with a damp paper towel and baking soda until a bright, shiny appearance is attained.

Section 6: Diagnostics and Troubleshooting

6.1 54e/56/1056/1057/1066/3081/4081/5081/XMT Diagnostics and Troubleshooting

Many Rosemount Instruments and Transmitters automatically search for fault conditions that would cause an error in the measured pH value. Refer to the applicable Reference Manual for a complete description of the transmitter's fault conditions.

Table 6-1 below lists some of the diagnostic messages that indicate a possible sensor problem. A more complete description of the problem and a suggested remedy corresponding to each message is also listed.

TABLE 6-1. Troubleshooting with Advanced Diagnostics

DIAGNOSTIC MESSAGE	DESCRIPTION OF PROBLEM	REMEDY
"Calibration Warning" CALLbrAtE	1. Aged glass. 2. Sensor not immersed.	1. Perform buffer calibration. 2. Be sure electrode measuring tip is in process.
"Cracked glass failure" GLASS FAIL	Broken or cracked glass.	Replace sensor.
"High reference impede" rEF FAIL or rEF WjArn	1. Liquid junction coated. 2. Reference Cell gel depleted. 3. Sensor not immersed.	1. Clean sensor; replace if necessary. 2. Replace sensor. 3. Be sure electrode measuring tip is in process.
"Input voltage high" "Input voltage low"	pH input shorted or sensor miswired.	Check wiring. Replace sensor if necessary.
"Old glass warning" GLASS WARN	1. Glass electrode worn out. 2. Sensor not immersed.	1. Replace sensor. 2. Be sure electrode measuring tip is in process.
"Reference offset err" (offline only) Std Err	Reference electrode poisoned.	Replace sensor.
"Ref voltage high" "Ref voltage low" "Sensor line open" LInE FAIL	1. Reference shorted or sensor miswired. 2. Sensor not immersed 1. Open wire between sensor and analyzer. 2. Interconnecting cable greater than 1000 ft.	Check wiring and installation. Replace sensor if necessary. 1. Check sensor wiring. 2. Relocate analyzer.
"Sensor miswired"	1. Open wire between sensor and analyzer. 2. Bad preamplifier.	1. Check wiring. 2. Replace preamplifier. (Code 02 only)
"Temp error high" "Temp error low" tEMP HI tEMP LO	1. Open or shorted RTD. 2. Temperature out of range.	1. Replace sensor. 2. Check process temperature.

6.2 Troubleshooting without Advanced Diagnostics

Table 6-2 below lists common problems, causes, and remedies typically encountered in process measurement.



TABLE 6-2. Troubleshooting without Advanced Diagnostics

Problem	Probable cause	Remedy
Meter reads off scale. (Display reads overrange).	Defective preamplifier	Replace preamplifier (for code 02 sensors). For code 01, replace sensor.
	T.C. element shorted	Check T.C. element as instructed in Section 6.1 and replace sensor if defective.
	Sensor not in process. Sample stream is low or air bubbles are present.	Make sure sensor is in process with sufficient sample stream (refer to Section 2.0 for installation details).
	Open glass electrode	Replace sensor.
	Reference element open - no contact	Replace sensor.
Display reads between 3 and 6 pH regardless of actual pH of solution or sample.	Electrode cracked	Replace sensor.
Meter or display indication swings or jumps widely in AUTO T.C. Mode.	T.C. element open	Check T.C. element as instructed in Section 6.1 and replace sensor if defective.
Span between buffers extremely short in AUTO T.C. Mode.	T.C. element open.	Check T.C. element as instructed in Section 6.1 and replace sensor if defective.
Sluggish or slow meter indication for real changes in pH level.	Electrode coated	Clean sensor as instructed in Section 6.2 or Section 6.3.2. Replace sensor if cracked.
	Electrode defective	Replace sensor.
Transmitter cannot be standardized.	Electrode coated or cracked	Clean sensor as instructed in Section 6.2 or Section 6.3.2. Replace sensor if cracked.
	Defective preamplifier	Replace preamplifier.
Transmitter short spans between two different buffer values.	Aged glass electrode or high temperature exposure.	Replace sensor.
	Electrode coated	Clean sensor as instructed in Section 6.2 or Section 6.3.2. Replace sensor if cracked.
	Air bubbles trapped in sensor end between glass bulb and sensor body	Shake the sensor in solution. See Section 2.0 for mounting guidelines.

TABLE 6-3. Rosemount 396P and 396PVP pH/ORP Replacement Parts and Accessories

PN	DESCRIPTION	QUANTITY
11275-01	Sensor Handrail Mounting Assembly	
2002011	Flow Cell, CPVC, 1 inch FNPT	
23242-02	Mounting Adapter, Insertion, 1¼-inch MNPT (304 S.S.) X 1" FNPT (PEEK)	
23646-01	Cable, Extension (Prepped) for Models 54, 81, 3081, 4081, and 5081	
23555-00	Junction Box with preamplifier, Models 54, 81, 3081, 4081, and 5081 compatible	
23557-00	Preamplifier, remote for Junction Box, Models 54, 81, 3081, 4081, and 5081 compatible	
22719-02	Junction Box, w/o Preamplifier	
33081-00	Adapter Insert, PEEK, 1 X 3/4-inch, for 23242-02	
9200254	Cable, 4 conductor, 22 AWG, shielded pair, for 1054/A/B, 2054, and 1181	
9200273	Cable, Extension (Unprepped) for Models 54, 81, 3081, 4081, and 5081	
23645-06	15 ft (4.6 m) cable with mating VP connector with BNC on transmitter end	
23645-07	15 ft (4.6 m) cable with mating VP connector with bare wires on transmitter end	
9210012	Buffer Solution, 4.01pH, 16 oz	4
9210013	Buffer Solution, 6.86pH, 16 oz	4
9210014	Buffer Solution, 9.18pH, 16 oz	4
9322014	Union, KYNAR ¹	
9320057	Union, PVC	
9120516	BNC Adapter	
915240-04	Tee, Flow-through, 2" PVC, 1" NPT	
9550175	O-ring for Mounting Adapter (23242-02)	
R508-160Z	ORP Standard Solution, 460mV ±10 at 20°C	
23550-00	Junction Box with Extension Board, Models 54, 81, 3081, 4081, and 5081 compatible	

Note: Please see [website](#) for most recent Declaration.

	
EU Declaration of Conformity No: RAD 1119 Rev. B	
pH/ORP Sensors	
We,	
Rosemount Inc. 8200 Market Boulevard Chanhassen, MN 55317-9685 USA	
declare under our sole responsibility that the product,	
Rosemount™ Sensor Models: 328A, 385, 385+ -04, 385+ -02.03, 385+ -03-12, 389-01, 389-01-10/11-50, 389-01-10/11-54, 389-01-12-50, 389-01-12-54, 389-01-12-55, 389-02, 389VP, 389VP-70, 396, 396P-01-10/13-50, 396P-01-10/13-54, 396P-01-12-50, 396P-01-12-54, 396P-01-12-55, 396P-01-55, 396VP, 396VP-70, 396R, 396RVP, 396RVP-70, 396P-02, 396PVP, 396PVP-70, 397, 398, 398VP, 398R, 398RVP, 398RVP-70, 3200HP, 3300HT, 3300HT VP, 3300HTVP-70, 3400HT, 3400HT VP, 3400HTVP-70, 3500P-01, 3500P-01-12, 3500P-02, 3500VP-01, 3500VP-01-12, 3500VP-02, 3800, 3800VP, 3900-01, 3900-02, 3900VP-01, 3900VP-02	
manufactured by,	
Rosemount Inc. 8200 Market Boulevard Chanhassen, MN 55317-9685 USA	
to which this declaration relates, is in conformity with the provisions of the European Union Directives, including the latest amendments, as shown in the attached schedule.	
Assumption of conformity is based on the application of the harmonized standards and, when applicable or required, a European Union notified body certification, as shown in the attached schedule.	
	Vice President of Global Quality
(signature)	(function)
Chris LaPoint	1-Feb-19; Shakopee, MN USA
(name)	(date of issue & place)
Page 1 of 3	



EU Declaration of Conformity

No: RAD 1119 Rev. B

ATEX Directive (2014/34/EU)

Baseefa10ATEX0156X– Intrinsically Safe

Equipment Group II, Category 1 G Ex ia IIC T4 Ga (-20°C ≤ Ta ≤ +60°C)

(exceptions noted below)

Model 328A Steam sterilizable pH sensor with integral cable
Model 385 Retractable pH/ORP sensor with integral cable
Model 385+ -04 pH/ORP sensor with integral cable
Model 385+ -02/03 pH/ORP sensor with integral cable & Smart preamplifier
Model 385+ -03-12 ORP sensor with integral cable & preamplifier: T4 (-20°C ≤ Ta ≤ +80°C), T5 (-20°C ≤ Ta ≤ +40°C)
Model 389-01 pH sensor with integral cable & Smart preamplifier
Model 389-01-10/11-50 pH sensor with integral cable & preamplifier: T4 (-20°C ≤ Ta ≤ +80°C) or T5 (-20°C ≤ Ta ≤ +40°C)
Model 389-01-10/11-54 pH sensor with integral cable & preamplifier: T4 (-20°C ≤ Ta ≤ +80°C) or T5 (-20°C ≤ Ta ≤ +40°C)
Model 389-01-12-50 ORP sensor with integral cable & preamplifier: T4 (-20°C ≤ Ta ≤ +80°C)
Model 389-01-12-54 ORP sensor with integral cable & preamplifier: T4 (-20°C ≤ Ta ≤ +80°C)
Model 389-01-12-55 ORP sensor with integral cable & preamplifier: T4 (-20°C ≤ Ta ≤ +80°C)
Model 389-02 pH/ORP sensor with integral cable
Model 389VP-70 pH sensor with Variopole connector & Smart preamplifier
Model 389VP pH/ORP sensor with Variopole connector
Model 396 TU pH sensor with integral cable
Model 396P-01-10/13-50 polypropylene pH sensor with integral cable & preamp: T4 (-20°C ≤ Ta ≤ 80°C) or T5 (-20°C ≤ Ta ≤ 40°C)
Model 396P-01-10/13-54 polypropylene pH sensor with integral cable & preamp: T4 (-20°C ≤ Ta ≤ 80°C) or T5 (-20°C ≤ Ta ≤ 40°C)
Model 396P-01-12-50 ORP sensor with integral cable & preamp: T4 (-20°C ≤ Ta ≤ +80°C)
Model 396P-01-12-54 ORP sensor with integral cable & preamp: T4 (-20°C ≤ Ta ≤ +80°C)
Model 396P-01-12-55 ORP sensor with integral cable & preamp: T4 (-20°C ≤ Ta ≤ +80°C)
Model 396P-01-55 pH sensor with integral cable & Smart preamp
Model 396VP TU pH sensor with Variopole connector
Model 396VP-70 TU pH sensor with Variopole connector & Smart preamplifier
Model 396R TU pH Retractable pH/ORP sensor with integral cable
Model 396RVP TU pH Retractable pH/ORP sensor with Variopole connector
Model 396RVP-70 TU pH Retractable pH sensor with Variopole connector & Smart preamplifier
Model 396P-02 TU pH Polypropylene pH/ORP sensor with integral cable
Model 396PVP TU pH Polypropylene pH/ORP sensor with Variopole connector
Model 396PVP-70 TU pH Polypropylene pH sensor with Variopole connector & Smart preamplifier
Model 397 TU pH sensor with integral cable
Model 398 TU pH pH/ORP sensor with integral cable
Model 398VP TU pH pH/ORP sensor with Variopole connector
Model 398R TU pH Retractable pH/ORP sensor with integral cable
Model 398RVP TU pH Retractable pH/ORP sensor with Variopole connector
Model 398RVP-70 TU pH Retractable pH sensor with Variopole connector & Smart preamplifier
Model 3200HP Flowing junction pH sensor with Variopole connector
Model 3300HT Insertion/submersion pH sensor with integral cable
Model 3300HTVP Insertion/submersion pH sensor with Variopole connector



EU Declaration of Conformity

No: RAD 1119 Rev. B

Model 3300HTVP-70 Insertion/submersion pH sensor with V ariopole connector & Smart preamplifier
Model 3400HT Retractable pH sensor with integral cable
Model 3400HTVP Retractable pH sensor with V ariopole connector
Model 3400HTVP-70 Retractable pH sensor with V ariopole connector & Smart preamplifier
Model 3500P-01 High performance pH sensor with integral cable & Smart preamplifier
Model 3500P-01-12 PerpH-X ORP sensor with integral cable & preamplifier: T4 (-20°C ≤ Ta ≤ +80°C)
Model 3500P-02 High performance pH sensor with integral cable
Model 3500VP-01 High performance pH sensor with V ariopole connector & Smart preamplifier
Model 3500VP-01-12 PerpH-X ORP sensor with V ariopole connector & preamplifier: T4 (-20°C ≤ Ta ≤ +80°C)
Model 3500VP-02 High performance pH sensor with V ariopole connector
Model 3800 Steam sterilizable pH sensor with single pole Eurocap connector
CE marking was first affixed to this product in 2011
Model 3800VP Steam sterilizable pH sensor with V ariopole connector
Model 3900-01 pH/ORP sensor with integral cable & Smart preamplifier
Model 3900-02 pH/ORP sensor with integral cable
Model 3900VP-01 pH sensor with V ariopole connector & Smart preamplifier
Model 3900VP-02 pH/ORP sensor with V ariopole connector

Special conditions for safe use:

- 1) All pH/ORP sensor models with a plastic enclosure or exposed plastic parts may provide an electrostatic ignition hazard and must only be cleaned with a damp cloth to avoid the danger of ignition due to a buildup of electrostatic charge.
 - 2) All pH/ORP sensor models with a metallic enclosure may provide a risk of ignition by impact or friction. Care should be taken during installation to protect the sensor from this risk.
 - 3) External connections to the sensor must be suitably terminated and provide a degree of protection of at least IP20.
- All pH/ORP sensor models are intended to be in contact with the process fluid and may not meet the 500V r.m.s test to earth. This must be taken into consideration at installation.

Harmonized Standards:

EN 60079-0:2012+A11:2013
EN 60079-11:2012

ATEX Notified Body for EC Type Examination Certificate & Quality Assurance

SGS FIMKO OY [Notified Body Number: 0598]
P.O. Box 30 (Särkiniementie 3)
00211 HELSINKI
Finland

含有China RoHS管控物质超过最大浓度限值的部件型号列表 396
List of 396 Parts with China RoHS Concentration above MCVs

部件名称 Part Name	有害物质 / Hazardous Substances					
	铅 Lead (Pb)	汞 Mercury (Hg)	镉 Cadmium (Cd)	六价铬 Hexavalent Chromium (Cr +6)	多溴联苯 Polybrominated biphenyls (PBB)	多溴联苯醚 Polybrominated diphenyl ethers (PBDE)
传感器组件 Sensor Assembly	X	O	O	O	O	O

本表格系依据SJ/T11364的规定而制作。

This table is proposed in accordance with the provision of SJ/T11364.

O: 意为该部件的所有均质材料中该有害物质的含量均低于GB/T 26572所规定的限量要求。

O: Indicate that said hazardous substance in all of the homogeneous materials for this part is below the limit requirement of GB/T 26572.

X: 意为在该部件所使用的所有均质材料里，至少有一类均质材料中该有害物质的含量高于GB/T 26572所规定的限量要求。

X: Indicate that said hazardous substance contained in at least one of the homogeneous materials used for this part is above the limit requirement of GB/T 26572.

部件名称 Part Name	组装备件说明 Spare Parts Descriptions for Assemblies
传感器组件 Sensor Assembly	传感器模块 Sensor Module

Intrinsically Safe Sensor Installation Drawing - FM

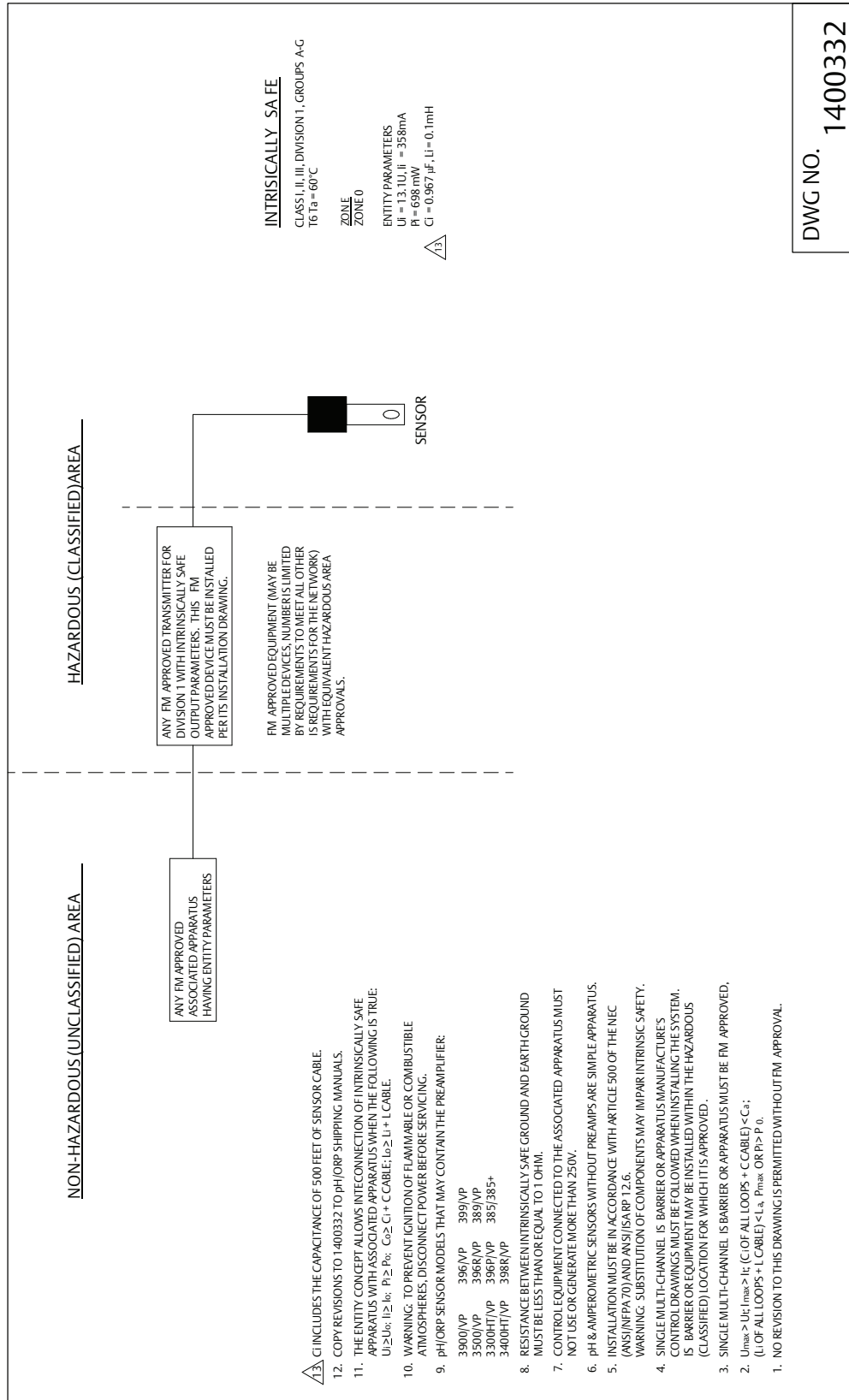

Section 7: Return of Material

7.1 General

For all repair or warranty inquires, please contact our Customer Care department.

www.Emerson.com/RosemountLiquidAnalysis



[Youtube.com/user/Rosemount](https://www.youtube.com/user/Rosemount)



[Twitter.com/Rosemount_News](https://twitter.com/Rosemount_News)



facebook.com/Rosemount

Emerson
8200 Market Blvd.
Chanhassen, MN 55317,
USA
Tel +1 800 999 9307
Fax +1 952 949 7001
Liquid.CSC@Emerson.com

©2019 Emerson. All rights reserved.

The Emerson logo is a trademark and service mark of Emerson Electric Co. Rosemount is a mark of one of the Emerson family of companies. All other marks are the property of their respective owners.

The contents of this publication are presented for information purposes only, and while effort has been made to ensure their accuracy, they are not to be construed as warranties or guarantees, express or implied, regarding the products or services described herein or their use or applicability. All sales are governed by our terms and conditions, which are available on request. We reserve the right to modify or improve the designs or specifications of our products at any time without notice.

ROSEMOUNT™

